

# Pumps, Filters & Heating

Pumps, Filters  
& Heating



# Clever-Pool Pump Inverter

- Four default settings:  
Low RPM (1200)  
Medium RPM (1800)  
High RPM (2100)  
Backwash (2800)



- Manual mode allows finer adjustment of pump speed
- Four timing periods allow different pump speeds to be automatically used at different times of day
- LCD screen showing motor speed and timings
- 2.5m cable to pump / 90cm cable to plug



## Clever-Pool Pump Inverter

DISCOUNT/ PRODUCT CODE	DESCRIPTION	PRICE EACH
K CPI001	Clever-Pool Inverter	349.00

- Up to 80% savings on pool pump energy consumption
- Simple installation
- Manual and Auto Mode
- Compatible with 95% of single speed pumps up to 1.5hp
- User friendly Control Panel

- Reduced wear and tear on your pool pump
- Reduced noise levels
- Improved filtration
- Set reduced speeds on your pump

## Capital outlay payback in under 12 months

### Typical cost of running a 1hp pool pump continually for 1 month (30 days)

Energy consumption per month..... 732kWh  
Price per kWh of electricity ..... 14p per kWh  
**Monthly expenditure ..... £102.51**

### Typical monthly running cost for the same pool with same pump linked to a Clever-Pool

Energy consumption per month..... 281.03kWh  
Price per kWh of electricity ..... 14p per kWh  
**Monthly expenditure ..... £39.34**

**Savings per month = £63.17**

Approximate capital outlay for Clever-Pool supplied and installed by a professional pool company ..... £540.00

The calculations shown are based on the following assumptions:

Pool pump is 1hp (0.746kW).

Output - 1.02kW Input - 73%

Illustrated calculation is based on Clever-Pool operating at the following parameters:

19 hours per day at 1,200rpm pump speed 173.91kWh per month

1 hour per day at 1,700rpm pool pump speed ..... 17.63kWh per month

4 hours per day at 2,100rpm pool pump speed ..... 89.50kWh per month

Figures may differ due to variable parameters, eg cost of kWh of energy, efficiency of pool circulation pump etc. Above figures based on a 30 day month.

All costs quoted include VAT



**Looking for competitive Pumps, Filters & Heating prices?  
Why not contact us NOW**



**Bespoke Sales LTD.**  
sales@bespokepoolsales.co.uk  
(UK) Tel: 1 001268 710425

# Filtration Control Panels

- Switches pump on when the water falls below set temperature
- Supplied complete with temperature probe
- Digital display of temperature
- Low and high set point are adjustable (on/off)

## Frost Stat

DISCOUNT/ PRODUCT CODE	DESCRIPTION	PRICE EACH
K DHG-2	Frost Protection Thermostat Controller	106.00



- Compact design
- Fitted time clock for filtration pump
- Suitable for .75hp to 1hp pumps as standard
- Option to supply circuit breaker for pumps up to 3hp
- Built-in 100w 12v Transformer for LED lights

## In Ground Control Panel

DISCOUNT/ PRODUCT CODE	DESCRIPTION	PRICE EACH
K PI310ID	Control Panel Filtration + Transformer 100w (in-ground)	192.00



- Compact design with wired remote time clock for small plant room
- Suitable for 0.75hp to 1hp pumps as standard
- Option to supply circuit breaker for pumps up to 3hp
- Built-in 100w 12v transformer for LED lights

## Control Panel

DISCOUNT/ PRODUCT CODE	DESCRIPTION	PRICE EACH
K PI31014LTEID	Control Panel (filtration + 100w transformer)	244.00

NB: Panel should be mounted inside



## Circuit Breakers

DISCOUNT/ PRODUCT CODE	DESCRIPTION	PRICE EACH
K GZ1M07	1.6 - 2.5amp (0.33hp = 2.2amp)	25.60
K GZ1M08	2.5 - 4amp (0.50hp = 3.12amp)	25.60
K GZ1M14	6 - 10amp (1.5hp = 7.6amp)	25.60
K GZ1M16	9 - 14amp (2hp = 10.4amp)	25.60

The above circuit breakers are to replace the standard units supplied with PI31014LTEID and PI310ID Control Panels. The adjustable dial must be set to the correct amp setting, in correspondence with the pumps registration plate.

# Plastica Argonaut

- Maintenance friendly
- Silent running
- Self priming up to 3m
- 2" suction, 2" delivery
- Stainless steel AISI 316 shaft
- Clear PC tank cover and large strainer basket
- PP tank, high chemical resistance
- Can be used with salt water up to a concentration of 0.4%

## Plastica Argonaut Single Phase

DISCOUNT/ PRODUCT CODE	DESCRIPTION	PRICE EACH
O3 AV50-2DN-S	0.33hp 4m³/h at 9m head. 10m head max	472.00
O3 AV75-2DN-S	0.5hp 7m³/h at 9m head. 13m head max	476.00
O3 AV100-2DN-S	0.75hp 10m³/h at 9m head. 14m head max	476.00
O3 AV150-2DN-S	1.0hp 14m³/h at 9m head. 15m head max	527.00
O3 AV200-2DN-S	1.5hp 18m³/h at 9m head. 16m head max	553.00
O3 AV250-2DN-S	2.0hp 23m³/h at 9m head. 17m head max	675.00

## Plastica Argonaut Three Phase

DISCOUNT/ PRODUCT CODE	DESCRIPTION	PRICE EACH
O3 AV50-3DN-S	0.33hp 4m³/h at 9m head. 10m head max	472.00
O3 AV75-3DN-S	0.5hp 7m³/h at 9m head. 13m head max	476.00
O3 AV100-3DN-S	0.75hp 10m³/h at 9m head. 14m head max	476.00
O3 AV150-3DN-S	1.0hp 14m³/h at 9m head. 15m head max	527.00
O3 AV200-3DN-S	1.5hp 18m³/h at 9m head. 16m head max	553.00
O3 AV250-3DN-S	2.0hp 23m³/h at 9m head. 17m head max	675.00

Performance Curve

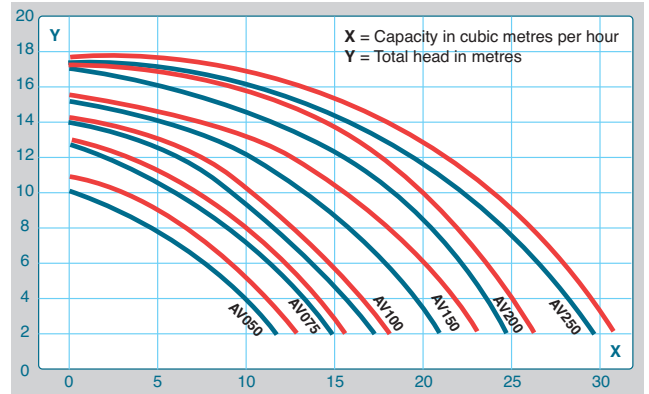

0.33HP = 0.24KW

0.75hp = 0.56kW

1.5hp = 1.12kW

0.5hp = 0.375kW

1hp = 0.75kW

2hp = 1.5kW

— Single phase

— Three phase



3 years warranty on pump body, 2 years on motor,  
1 year on pump seal

1-Phase	A	B	INPUT kW
AV50-2DN-S	144	533	0.45
AV75-2DN-S	164	533	0.60
AV100-2DNS-S	164	533	0.70
AV150-2DNS-S	164	561	1.00
AV200-2DNS-S	174	561	1.30
AV250-2DNS-S	174	564	1.80

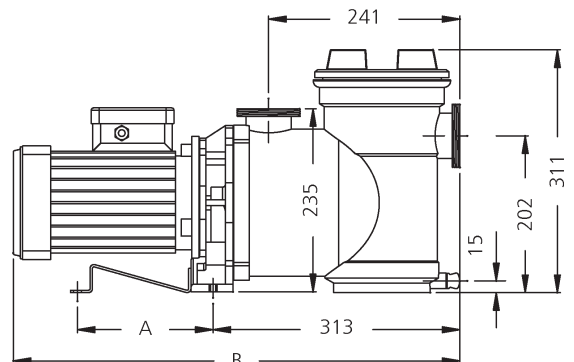
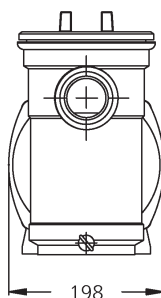

# Plastica AG Pump Series

- Maintenance friendly
- Self priming up to 1-8m
- Unrivalled whisper running
- 2 1/4" BSP External threaded ports
- Union ABS 50mm ID & 1.5" ID
- Polypropylene glass filled pump body
- Stainless steel AISI 316 steel shaft
- Can be used with salt water up to a concentration of 0.4%
- Good chemical resistance

## Plastica AG Pumps

DISCOUNT/ PRODUCT CODE	DESCRIPTION	PRICE EACH
O4 AG8-2DC	0.25hp - 4m <sup>3</sup> /h at 6m head. 8m head max	276.00
O4 AG10-2DC	0.33hp - 5m <sup>3</sup> /h at 6m head. 10m head max	276.00
O4 AG14-2DC	0.50hp - 10m <sup>3</sup> /h at 6m head. 12m head max	276.00
O4 AG16-2DC	0.66hp - 12m <sup>3</sup> /h at 6m head. 13m head max	283.00

Performance Curve

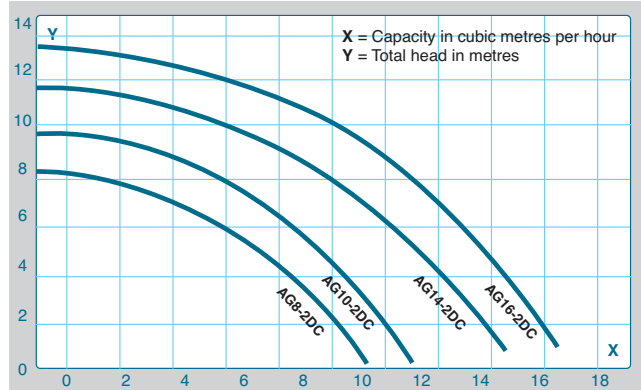

0.25hp = 0.19kW  
0.50hp = 0.37kW

0.33hp = 0.25kW  
0.66hp = 0.49kW



3 years warranty on pump body, 2 years on motor,  
1 year on pump seal

1-Phase	INPUT kW
AV8-2DC	0.29
AV10-2DC	0.36
AV14-2DC	0.49
AV16-2DC	0.67

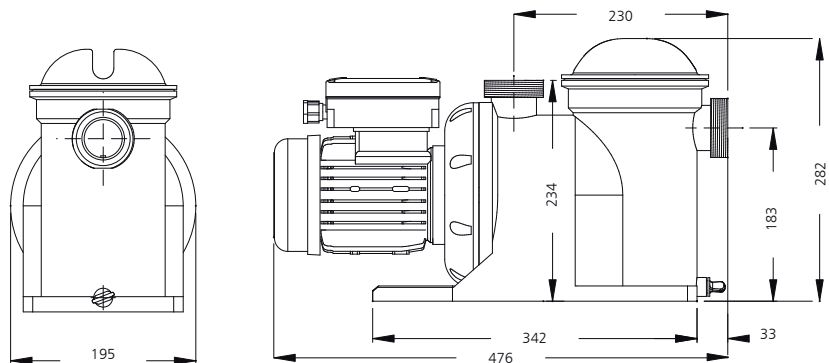

# iFlo™ Pumps

- Proven reliability
- Outstanding value
- Simple to install
- Ultra quiet
- 1.5" suction, 1.5" delivery

## iFlo 500

DISCOUNT/ PRODUCT CODE	DESCRIPTION	PRICE EACH
O2 SFP030 0.75hp		265.50
O2 SFP100 1hp		282.00
O2 SFP150 1.5hp		294.00

Performance Curve

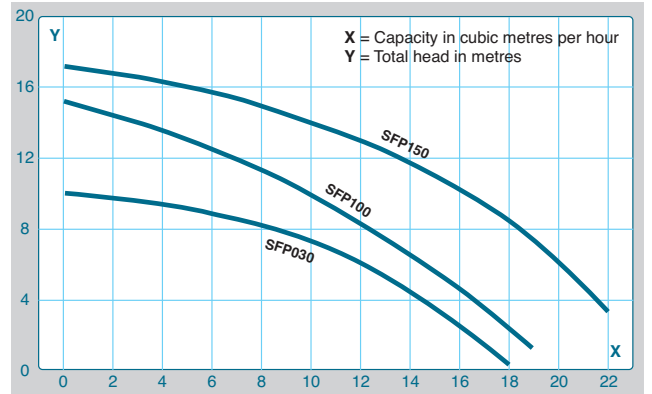

0.75hp = 0.56kW

1.0hp = 0.75kW

1.5hp = 1.12kW

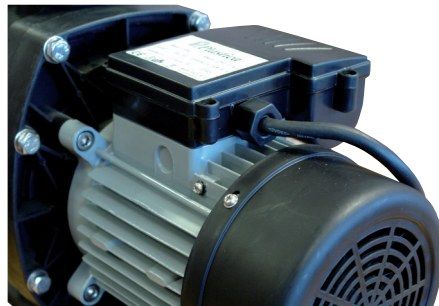
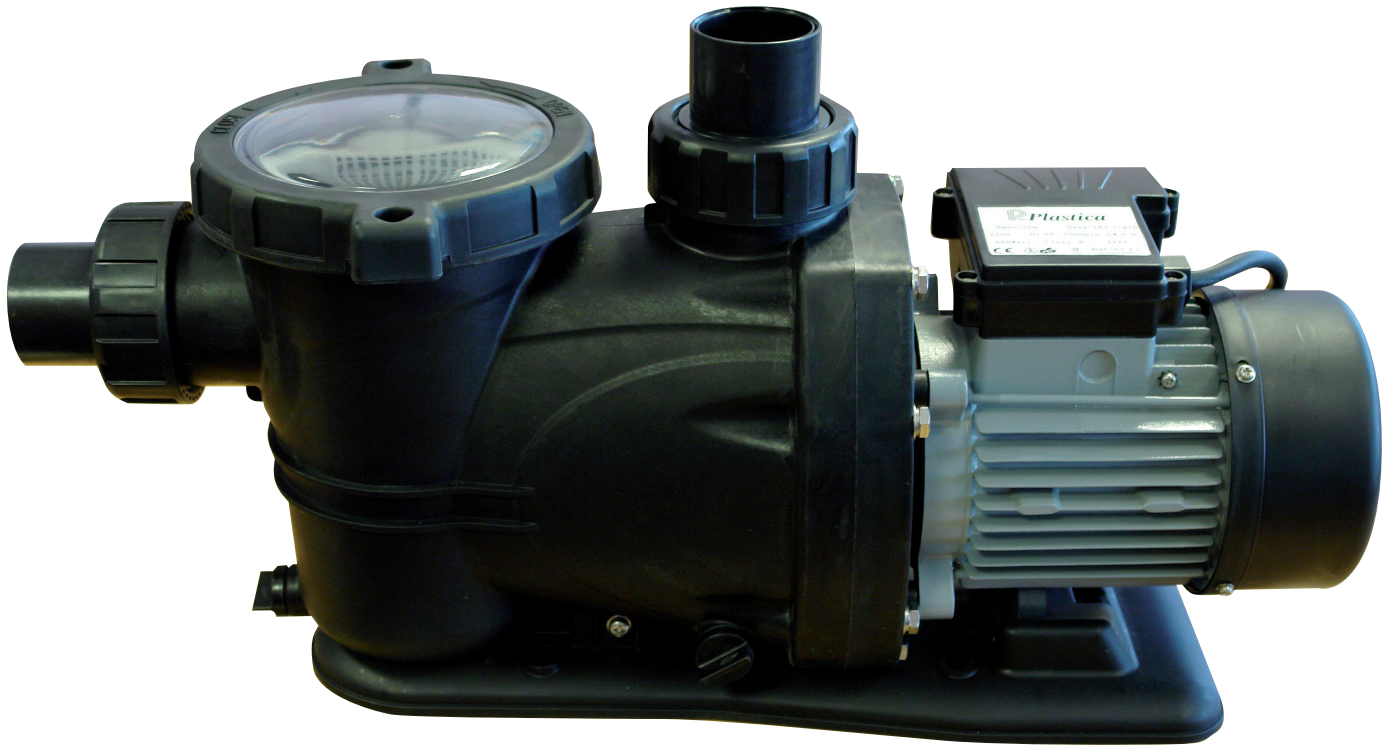

iFlo™ is a registered trademark of Plastica Ltd.

# Endurance™

- Rapid self priming
- Union connections for quick installation and servicing
- Extra large pump strainer basket for reduced emptying frequency
- 1.5" suction, 1.5" delivery – 2" on 1.5hp

## Endurance™

DISCOUNT/ PRODUCT CODE	DESCRIPTION	PRICE EACH
O2 EPU050	0.5hp – 10m³ per hour	425.00
O2 EPU075	0.75hp – 11m³ per hour	435.00
O2 EPU100	1hp – 16m³ per hour	475.00
O2 EPU150	1.5hp – 21.5m³ per hour	527.00

Performance Curve

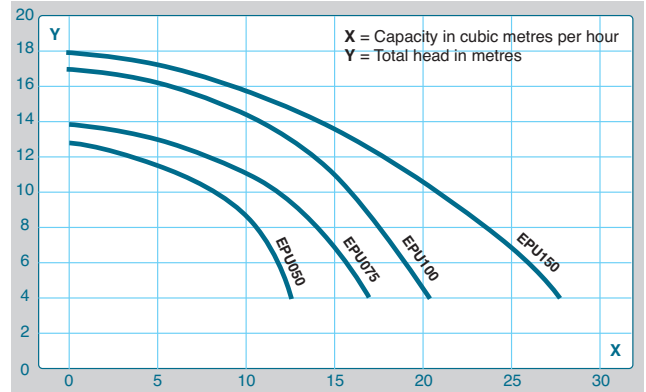

0.5hp = 0.375kW  
0.75hp = 0.56kW

1.0hp = 0.75kW  
1.5hp = 1.12kW



# Sta-Rite 5P2R™

- Manufactured from glass reinforced composite resin
- Temperature and corrosion resistant
- One piece shaft
- 1.5" suction, 1.5" delivery
- Self-priming diffuser design for fast priming
- High load impeller for maximum performance
- Stainless steel locking clamp for quick and easy service
- Multiple drain locations for quick winterising

Performance Curve

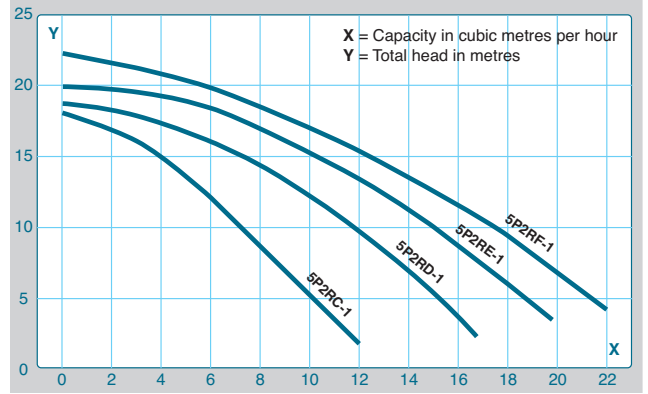

0.5hp = 0.375kW

0.75hp = 0.56kW

1hp = 0.75kW

1.5hp = 1.12kW

## Sta-Rite 5P2R™

DISCOUNT/ PRODUCT CODE	DESCRIPTION	PRICE EACH
O 5P2RC-1	0.50hp – 8.5m³ per hour	637.00
O 5P2RD-1	0.75hp – 12.5m³ per hour	660.85
O 5P2RE-1	1.00hp – 16m³ per hour	709.85
O 5P2RF-1	1.50hp – 19m³ per hour	791.60

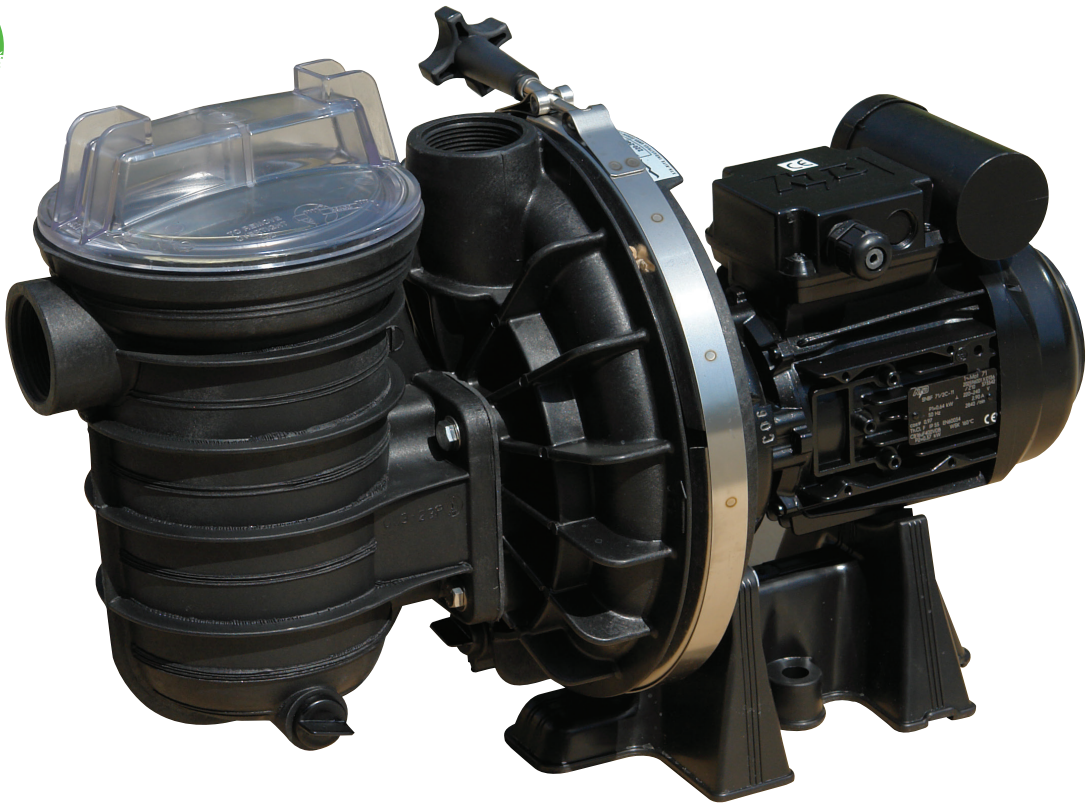



# Pentair Freeflo

- Drop-in replacement for Swimway Pump
- Transparent lid for easy inspection of strainer basket
- Large self-aligning basket
- 50mm swivel union fittings for better sealing
- Discharge is 90° rotatable
- Additional drain plug for servicing pump housing
- Heavy duty long life IP55 rated motor

## Pentair Freeflo

DISCOUNT/ PRODUCT CODE	DESCRIPTION	PRICE EACH
O FFL-031 0.33hp		288.00
O FFL-051 0.5hp		299.00
O FFL-071 0.75hp		331.00
O FFL-101 1.0hp		367.00
O FFL-151 1.5hp		492.50

Performance Curve

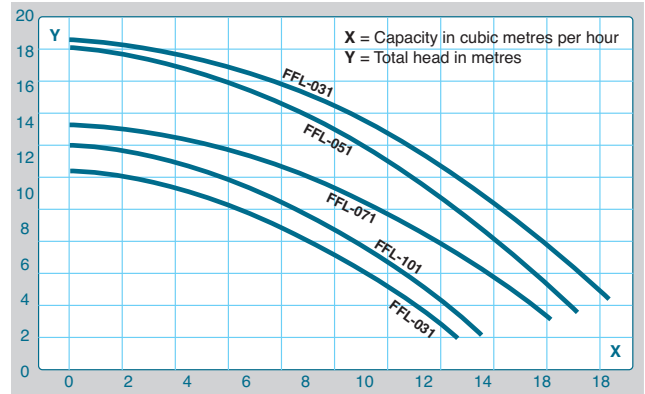

0.33hp = 0.25kW  
0.5hp = 0.375kW

0.75hp = 0.55kW  
1hp = 0.75kW

1.5hp = 1.1kW



90° rotational discharge

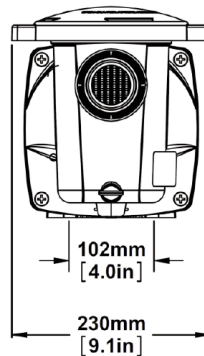
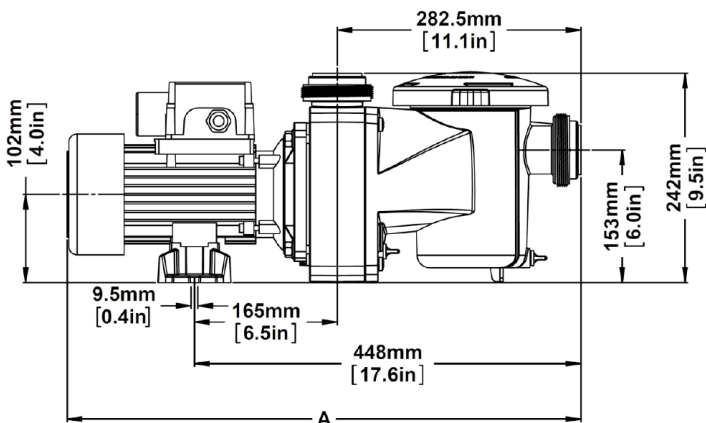

OUTPUT POWER		DIMENSION "A"
WATTS	HP	
250W	1/3	540 mm (21.3 in)
370W	1/2	540 mm (21.3 in)
550W	3/4	562 mm (22.2 in)
750W	1	562 mm (22.2 in)
1100W	1.5	600 mm (23.6 in)

# Lacronite™

- Direct replacement for 5P2R pump
- Pump basket approx 70% larger than 5P2R
- 316 grade stainless steel mechanical seal, suitable for saltwater pools
- Self priming with strong, efficient, Noryl impeller
- 1.5" quick connect unions
- 3 years warranty on pump body, 2 years on motor, 1 year on mechanical seal

Performance Curve

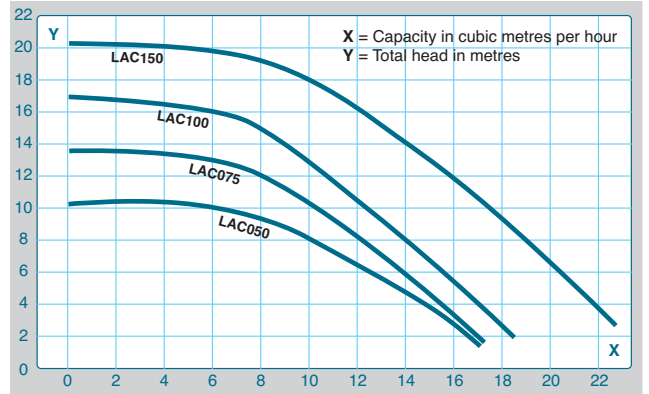

## Lacronite™

DISCOUNT/ PRODUCT CODE	DESCRIPTION	PRICE EACH
O LAC050 0.5hp		550.80
O LAC075 0.75hp		575.00
O LAC100 1hp		617.00
O LAC150 1.5hp		679.00

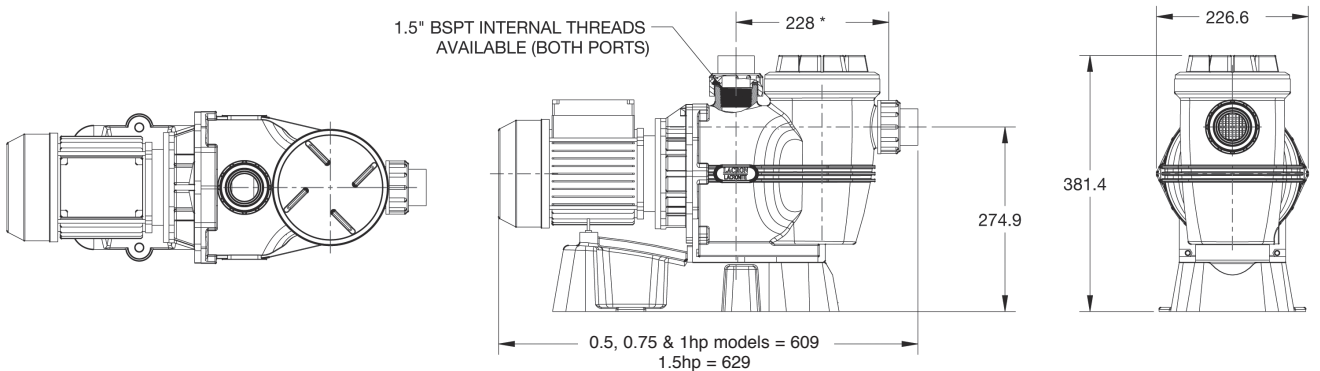

Pumps, Filters & Heating

# Espa Silen S

- Manufactured in Europe from glass-loaded polypropylene
- 0.9 litre pre-filter capacity
- Single phase motor with built-in thermal protection
- 4m suction and lift
- Can be used with salt water up to a concentration of 0.4%
- 2" Suction, 1.5" Delivery
- 1p 55 protection
- 10.000 hours P2 Capacitor with aluminium casing
- Motor shaft in AISI 431 mechanical seal in AISI 316

## Espa Silen S

DISCOUNT/ PRODUCT CODE	DESCRIPTION	PRICE EACH
O SILS060	0.60hp – 12m <sup>3</sup> per hour	467.00
O SILS075	0.75hp – 15m <sup>3</sup> per hour	483.00
O SILS100	1.00hp – 18m <sup>3</sup> per hour	495.00
O SILS150	1.5hp – 22m <sup>3</sup> per hour	570.00

Performance Curve

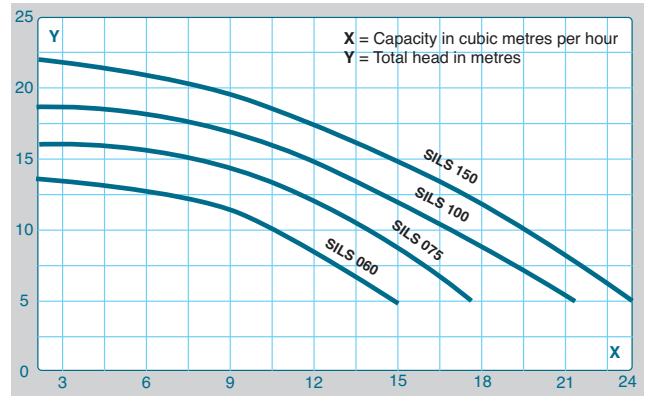

0.33hp = 0.25kW

0.75hp = 0.56kW

1.5hp = 1.12kW

0.5hp = 0.375kW

1hp = 0.75kW

Pumps, Filters  
& Heating

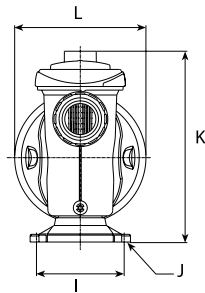
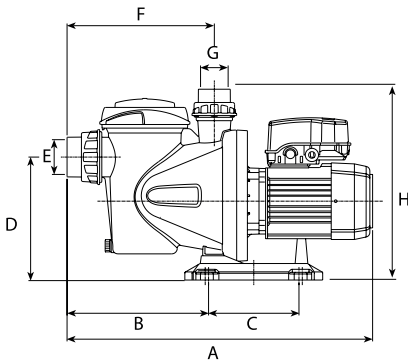

**NB: Not a like for like fit with last Silen model (now has 2" suction)**

Model	A	B	C	D	E	F	G	H	I	J	K	L
SILEN S 60 12	495	211	170	225	2 <sup>3</sup> / <sub>4</sub> "	225	2 <sup>1</sup> / <sub>4</sub> "	308	159	Ø9	238	8,9
SILEN S 75 15	495	211	170	225	2 <sup>3</sup> / <sub>4</sub> "	225	2 <sup>1</sup> / <sub>4</sub> "	308	159	Ø9	238	10,2
SILEN S 100 18	495	211	170	225	2 <sup>3</sup> / <sub>4</sub> "	225	2 <sup>1</sup> / <sub>4</sub> "	308	159	Ø9	238	10,2
SILEN S 150 22	495	211	170	225	2 <sup>3</sup> / <sub>4</sub> "	225	2 <sup>1</sup> / <sub>4</sub> "	308	159	Ø9	238	13,5

# Pentair Blueflo® Pumps

- Superior hydraulic performance
- Designed for continuous operation and thermally protected
- Large sealed "2RSC3" type bearings for high temperature handling and extended motor life
- Corrosion resistant with 316 Stainless Steel Motor Shaft-end and metal free impellers for salt chlorination usage
- Integrated power cord and ON/OFF switch for easy installation\*
- Integrated Electronic Protection Logic-Safe™. Protection against following possible issues\*:
  - Dry running
  - Motor overload
  - Water temperature overheating

Performance Curve

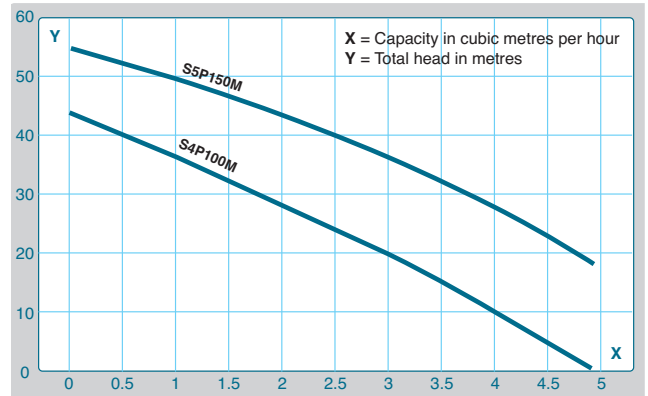

## Blueflo® Booster Pump

DISCOUNT/ PRODUCT CODE	DESCRIPTION	PRICE EACH
O P-BFL-101 1hp		392.00
O P-BFL-151 1.5hp		436.00

To connect to 1.5" pipework please use two of each of the below fittings:

## Installation Accessories

DISCOUNT/ PRODUCT CODE	DESCRIPTION	PRICE EACH
H PVC335 1" Barrell Nipple P/T		2.50
H PVC925 1.5" - 1" P/P Bush		1.60

# Pentair Blueflo® Lite Pumps

- Superior hydraulic performance
- Designed for continuous operation and thermally protected
- Large sealed "2RSC3" type bearings for high temperature handling and extended motor life
- Corrosion resistant with 316 Stainless Steel Motor Shaft-end and metal free impellers for salt chlorination usage

Performance Curve

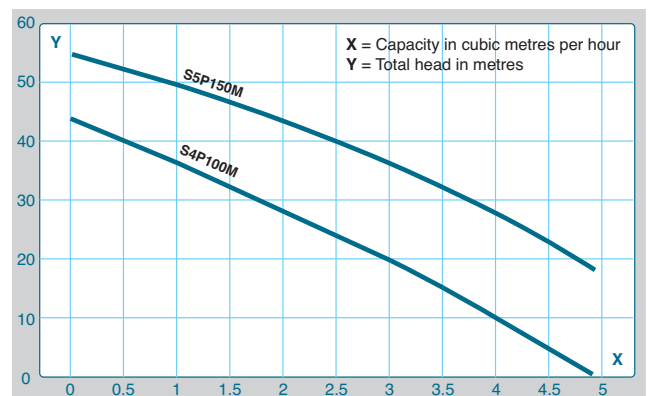

## Blueflo® Lite Booster Pump

DISCOUNT/ PRODUCT CODE	DESCRIPTION	PRICE EACH
O P-BFL-101-L 1hp		333.00

To connect to 1.5" pipework please use two of each of the below fittings:

## Installation Accessories

DISCOUNT/ PRODUCT CODE	DESCRIPTION	PRICE EACH
H PVC335 1" Barrell Nipple P/T		2.50
H PVC925 1.5" - 1" P/P Bush		1.60



# ESPA Multipool N

## Materials

Pump body, base and diffusers in polymeric materials.  
 Shaft in stainless steel AISI 431. Wet end with AISI 431 metallic components. Mechanical seal in graphite and alumine. Motor housing in aluminium L-2521. Windings impregnated with polyester resin.

## Motor

Asynchronous, two poles.  
 IP 55 protection.  
 Class F insulation.  
 Continuous operation.  
 Single-phase with built-in thermal protection.

- Multi-stage booster pumps for pool cleaners.
- Designed for operation with chlorinated and, salt water.

## Performance Curve

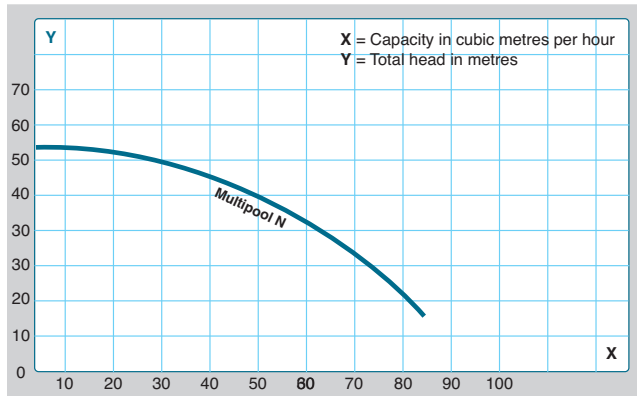

1hp = 0.75kW

# ESPA Multipool N

DISCOUNT/ PRODUCT CODE	DESCRIPTION	PRICE EACH
O MPN100	Multipool N 1.00hp	333.00

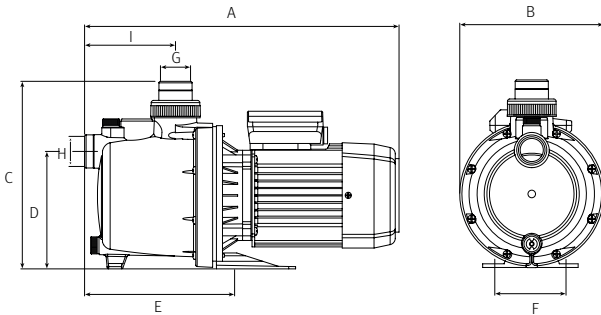

Pumps, Filters & Heating

# Sta-Rite Boost-Rite® Booster Pump

- Pump for pressure-side cleaners or water boosting applications
- Multi-stage design for maximum pressure
- Designed for continuous operation
- Built-in thermal protection
- Quiet operation
- Saltwater resistant design
- 1" BSP
- Single phase 220v-240v

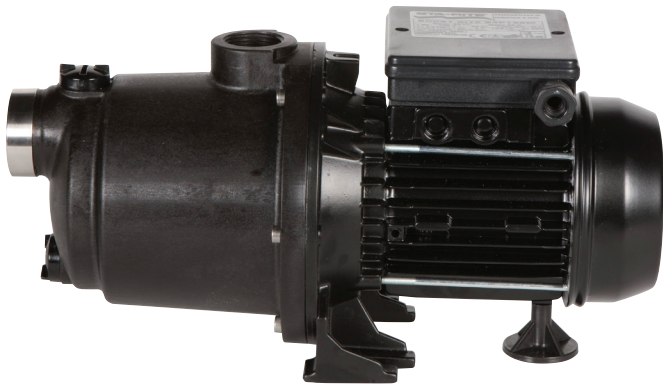

## Performance Curve

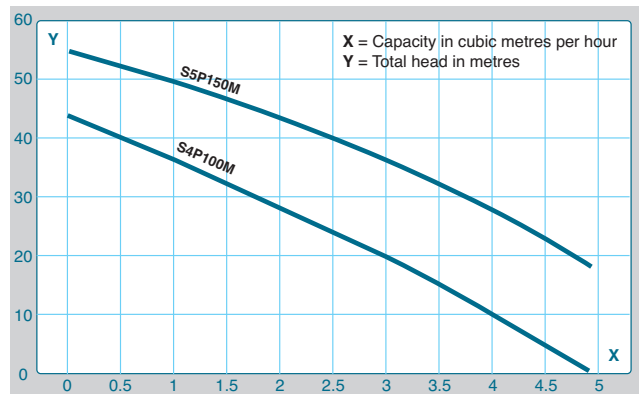

1hp = 0.75kW

1.5hp = 1.12kW

# Sta-Rite Boost-Rite Booster Pump

DISCOUNT/ PRODUCT CODE	DESCRIPTION	PRICE EACH
O S4P100M	1hp	337.00
O S5P150M	1.5hp	415.00

To connect to 1.5" pipework please use two of each of the opposite fittings:

## Installation Accessories

DISCOUNT/ PRODUCT CODE	DESCRIPTION	PRICE EACH
H PVC335	1" Barrell Nipple P/T	2.50
H PVC925	1.5" - 1" P/P Bush	1.60

## Endurance™ Filter

- Laminated fibreglass tank reinforced with polyester resin
- 300mm lid for easy media change
- Complete with valve and pressure gauge

### Filter with Valve & Gauge

DISCOUNT/ PRODUCT CODE	DESCRIPTION	PRICE EACH
O2 EFI050K	500mm (20") Filter, 1.5" 6-way Valve	448.00
O2 EFI060K	600mm (24") Filter, 1.5" 6-way Valve	509.00
O2 EFI075K	750mm (30") Filter, 2" 6-way Valve	776.00

Model	Size	Media Required
EFI050	20"	3 bags
EFI060	24"	6 bags
EFI075	30"	11 bags

(for guidance only)

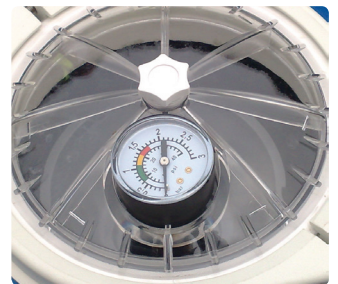

## Triton®

- 360° diffuser
- Clear lid for observation
- Easy to use water drain
- Complete with valve and gauge
- One piece reinforced tank
- UV resistant
- 8.5" closure
- 3.5 bar maximum operating pressure
- 50°C maximum operating temperature
- Manufactured in Europe

### Triton®

DISCOUNT/ PRODUCT CODE	DESCRIPTION	PRICE EACH
O F-19S8-TRV	19"	640.50
O F-24S8-TRV	24"	753.50
O F-30S8-TRV	30"	1113.00
O F-36S8-TRV	36"	1542.50

Model	Size	Media Required
F-19S8-TRV	19"	3 bags
F-24S8-TRV	24"	6 bags
F-30S8-TRV	30"	11 bags
F-36S8-TRV	36"	17 bags

(for guidance only)



# Triton® II with Clearpro Technology®

- Improved lateral design for finer filtration
- 360° diffuser
- Clear lid for observation
- Easy to use water drain
- Complete with valve and gauge
- One piece reinforced tank
- UV resistant
- 8.5" closure
- 3.5 bar maximum operating pressure
- 50°C maximum operating temperature



## Triton® II

DISCOUNT/ PRODUCT CODE	DESCRIPTION	PRICE EACH
O F-19S8-TRCP 19"		694.00
O F-24S8-TRCP 24"		817.00
O F-30S8-TRCP 30"		1209.00
O F-36S8-TRCP 36"		1672.50

Model	Size	Media Required
F-19S8-TRCP	19"	3 bags
F-24S8-TRCP	24"	6 bags
F-30S8-TRCP	30"	11 bags
F-36S8-TRCP	36"	17 bags

(for guidance only)

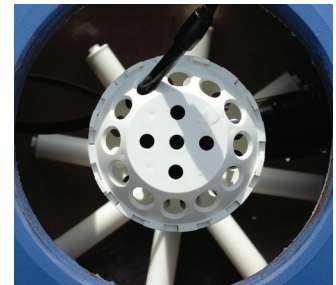

Pumps, Filters  
& Heating

- ClearPro® is a patented technology by Pentair to reach a very fine level of filtration. Somewhat four times better than with a conventional sand filter (about 10µ vs 40µ)

## ClearPro Technology®

- This purity is achieved thanks to new porous laterals.
- The laterals act like additional filters creating an extra barrier against the finest particles.
- As a result, the water is crystal quality
- ClearPro® approaches DE filter clarity with sand functionality.

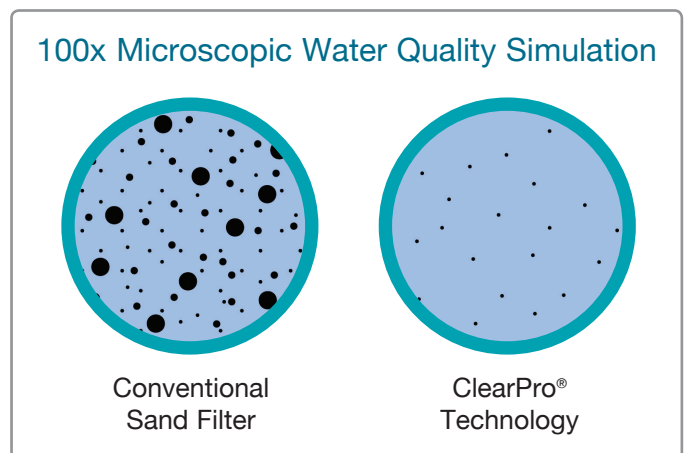
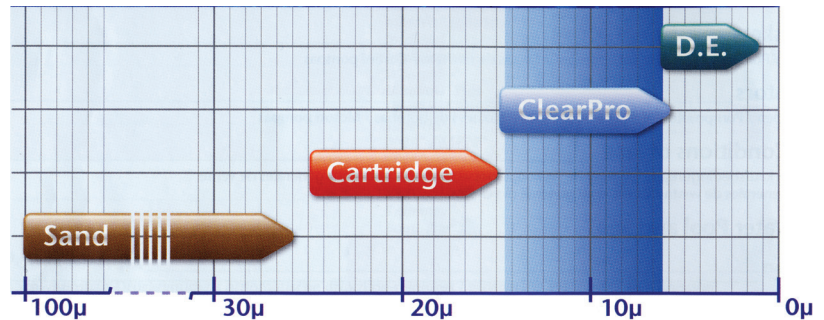

# Tagelus®

- One piece reinforced fibreglass tank
- Valve can be fitted in any position
- Easy drainage
- Complete with valve and gauge
- One piece reinforced tank
- 6-Way multiport valve
- 3.5 bar maximum operating pressure
- 50°C maximum operating temperature

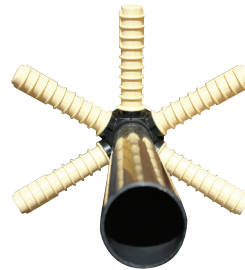

## Tagelus®

DISCOUNT/ PRODUCT CODE	DESCRIPTION	PRICE EACH
O F-19T6-TAG 19"		451.00
O F-24T6-TAG 24"		540.00
O F-30T8-TAG 30"		804.00

Model	Size	Media Required
F-19T6-TAG	19"	4 bags
F-24T6-TAG	24"	7 bags
F-30T6-TAG	30"	12 bags

(for guidance only)

# Lacron SureFlow LSR Sand Filter

- 16" to 30" models held in stock
- High quality construction
- Complete with valve and pressure gauge

## Lacron SureFlow LSR

DISCOUNT/ PRODUCT CODE	DESCRIPTION	PRICE EACH
O LDF016 16" with 1.5" MPV		494.00
O LDF018 18" with 1.5" MPV		565.00
O LDF024 24" with 1.5" MPV		707.00
O LDF030 30" with 2" MPV		1185.00

Model	Size	Media Required
LDF016	16"	2 bags
LDF018	18"	3 bags
LDF024	24"	5 bags
LDF030	30"	8 bags

(for guidance only)

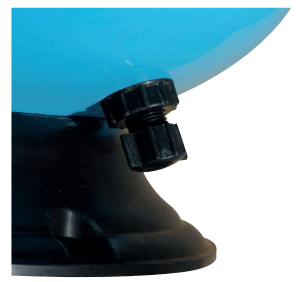
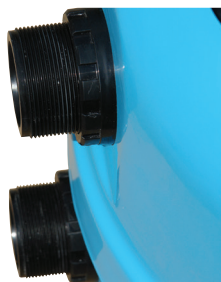



## Endurance™ Filter Pump Pack

- Rapid self priming pump
- Union connections for quick installation and servicing
- Extra large pump strainer basket for reduced emptying frequency
- Laminated fibreglass filter tank reinforced with polyester resin
- 300mm lid for easy media change
- Complete with valve and pressure gauge
- 1.5" suction, 1.5" delivery (2" on 1.5hp)

### Lacron SureFlow LSR

DISCOUNT/ PRODUCT CODE	DESCRIPTION	PRICE EACH
O2 FPC5075K	0.75hp Pump, 20" Filter, 1.5" 6-way Valve	830.00
O2 FPC60100K	1hp Pump, 24" Filter, 1.5" 6-way Valve	935.00
O2 FPC75150K	1.5hp Pump, 30" Filter, 2" 6-way Valve	1238.00



Pumps, Filters  
& Heating

Endurance™ is a registered trademark of Plastica Ltd.

## iFlo™ 500 Filter Pump Pack

- 0.75hp pump
- 500mm filter tank
- Outstanding value
- Simple to install
- Ultra quiet, self priming
- Quality 6-way 7-position multi-port valve

### iFlo 500

DISCOUNT/ PRODUCT CODE	DESCRIPTION	PRICE EACH
O2 SFP500	Filter Pump Pack	383.00

Model	Size	Media Required
SFP500	20"	2 bags

(for guidance only)



# Krystal Clear™ Filter Pump Packs

- 6-way multiport valve
- 24 hour automatic timer
- Pressure gauge
- Comes in display box
- Complete with connectors and flexible pipe for Intex pool

## Krystal Clear

DISCOUNT/ PRODUCT CODE	DESCRIPTION	PRICE EACH
L 56672BS	0.95hp 9.2m³ per hour filter pump pack	249.00

56672BS specification:

- 9.2m³ per hour
- 16" (410mm) diameter tank
- 0.95hp pump
- 38kg glass media capacity
- 55kg sand capacity

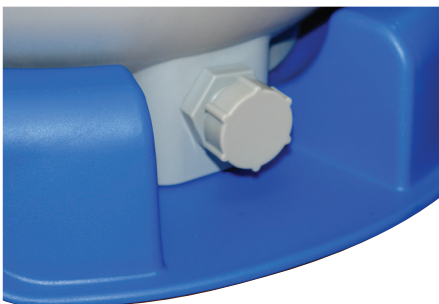

Connectors and flexible pipe included

## Rigid Pipe Conversion Kit

DISCOUNT/ PRODUCT CODE	DESCRIPTION	PRICE EACH
L AFP071	Rigid pipe conversion kit	36.60

- Converts to 1.5" pipe

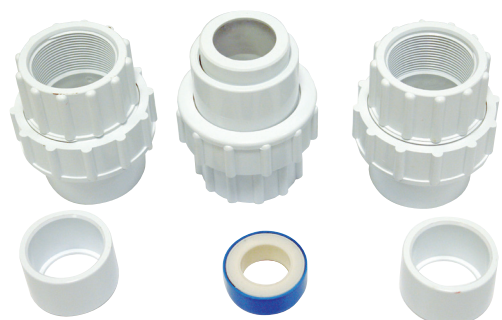

Rigid Pipe Conversion Kit – AFP071

Pumps, Filters  
& Heating

## Sta-Rite Azur/FreeFlo™ Filter Pump Pack

- Fast and easy set up
- Single piece thermoplastic moulded tank
- Large strainer basket reduces emptying frequency
- Union connections for quick installation and servicing
- Unified pump/filter base for secure system installation

### Azur/FreeFlo™ Filter Pump Pack

DISCOUNT/ PRODUCT CODE	DESCRIPTION	PRICE EACH
O FS-15A6-FF10	0.33hp Pump, 375mm Filter, 6-way Valve	489.00
O FS-19A6-FF12	0.5hp Pump, 475mm Filter, 6-way Valve	540.00
O FS-22A6-FF15	0.75hp Pump, 560mm Filter, 6-way Valve	607.00

Model	Size	Media Required
FS-15A6-FF10	15"	2 bags
FS-15A6-FF12	19"	3 bags
FS-15A6-FF15	22"	4 bags

(for guidance only)



Pumps, Filters  
& Heating

## Krystal Clear™ Filter Pump Packs

- Suitable for above ground pools
- 6-way multiport valve
- 24 hour automatic timer
- Pressure gauge
- Complete with connectors and flexible pipe for Intex pool

### Krystal Clear

DISCOUNT/ PRODUCT CODE	DESCRIPTION	PRICE EACH
L 28644	0.25hp 4m³ per hour filter pump pack	199.00
L 28646	0.5hp 6m³ per hour filter pump pack	228.00
L 28648	0.6hp 8m³ per hour filter pump pack	297.00

28644 specification:

- 4m³ per hour flow rate
- 10" (254mm) diameter tank
- 0.25hp pump
- 8.5kg glass media capacity
- 12kg sand capacity

28648 specification:

- 8m³ per hour flow rate
- 14" (360mm) diameter tank
- 0.6hp pump
- 25kg glass media capacity
- 36kg sand capacity

28646 specification:

- 6m³ per hour flow rate
- 12" (350mm) diameter tank
- 0.5hp pump
- 16kg glass media capacity
- 23kg sand capacity
- Basket included on pump



Krystal Clear – 28644BS

Connectors and  
flexible pipe included

# Waterco Cartridge Filters

- 1.5" connections
- 11.4m<sup>3</sup>/hour maximum flow
- 3.5 bar working pressure

## Waterco Cartridge Filters

DISCOUNT/ PRODUCT CODE	DESCRIPTION	PRICE EACH
K WCF100	Top Load Filter and Base (50 sq ft)	112.00

## Replacement Cartridge

DISCOUNT/ PRODUCT CODE	DESCRIPTION	PRICE EACH
S3 62010	50sq ft Cartridge for WCF100	82.50



# Cartridge Filter Pump Units

- Easy installation
- Double insulated with air release valve
- Automatic timer

## Cartridge Filter Pump Units

DISCOUNT/ PRODUCT CODE	DESCRIPTION	PRICE EACH
L 28602BS	1,136 litres per hour	38.00
L 28604BS	1,798 litres per hour	50.00
L 28638BS	2,839 litres per hour	70.00
L 28636BS	4,466 litres per hour	130.00
L 29060	Accessory Hose 1.5m x 38mm	16.30

Type H filter cartridge fits filter model 28602

Type A filter cartridge fits filter models 28604, 28638 and 28636

Type B filter cartridge fits filter model and 28634

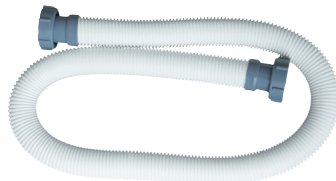

Accessory Hose – 29060

- 28602BS suitable for 10' Metal Frame, 8' & 10' Easy Set Pool
- 28604BS suitable for 12' Metal Frame, 8' & 12' Easy Set Pool
- 28638BS suitable for 15' Metal Frame & 15' Easy Set Pool
- 28636BS suitable for 18' Metal Frame Pool



28604BS



28638BS

## Cartridges for Above Ground Filter Pump Units

DISCOUNT/ PRODUCT CODE	DESCRIPTION	PRICE EACH
S 29007	Intex Type H Filter Cartridge	3.70
S 29000	Intex Type A Filter Cartridge	4.20
S 29002	Intex Type A Filter Cartridges Twin Pack	8.00
S 29003	Intex Type A Filter Cartridges Triple Pack	11.50
S 29005	Intex Type B Filter Cartridge	9.90

## Filter Cartridge Cleaners

DISCOUNT/ PRODUCT CODE	DESCRIPTION	PRICE EACH
S 29082	Multi-function Cartridge Cleaner	6.00
S3 FFLOSSV1	Filter Flossing Cleaning Tool	24.99



Power Pic Cleaning Tool FP1CV1



FilterFlosser Cleaning Tool FFLOSSV1



Multi-function Cartridge Cleaner 29082

# Pleatco Advanced™

THE NEW STANDARD IN POOL & SPA FILTRATION

**ANTIMICROBIAL CAPS**  
**ADVANCED MEDIA**  
**FREE FLOW CORES®**  
**SUPERBAND BANDS**

**ANTIMICROBIAL CAPS**  
**ADVANCED MEDIA**  
**FREE FLOW CORES®**  
**SUPERBAND BANDS**

**ANTIMICROBIAL CAPS**  
**ADVANCED MEDIA**  
**FREE FLOW CORES®**  
**SUPERBAND BANDS**

**POOL CERTIFIED FILTERS**  
TRADECERTIFIED.COM

**SPA CERTIFIED FILTERS**  
TRADECERTIFIED.COM

**PLEATCO ADVANCED POINT BONDED FABRICS®**  
**UNLIKE ANY OTHER BONDED FILTRATION MEDIA!**  
COMPLETELY UNIQUE AND EXCLUSIVE TO PLEATCO.

**Pleatco Advanced POOL™**  
THE NEW STANDARD IN POOL FILTRATION

**Pleatco Advanced SPA™**  
THE NEW STANDARD IN SPA FILTRATION

Pumps, Filters & Heating



**HEAVIER  
PLEATCO  
ADVANCED  
POINT  
BONDED  
FILTRATION  
FABRIC**

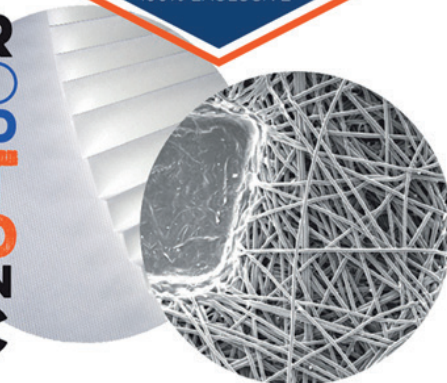

**FINER  
FIBERS  
GREATER  
DIRT CAPTURING WET  
AREA  
GREATER  
FLOW**

## GAME CHANGER

No other filtration media comes close!

**4 oz**

**Pleatco Advanced POOL™**  
POINT BONDED FILTRATION FABRIC

**Pleatco Advanced SPA™**  
POINT BONDED FILTRATION FABRIC

**3.2 oz**

**SEE OUR SEPARATE FILTER CARTRIDGE CATALOGUE**

Your path to  
paradise....



★★★★★  
5 star incentive program

The Partners Incentive Program is a rewards platform to provide our channel partners with the most innovative products available, intuitive marketing tools to build your customer base, stellar customer service, and sales incentives to help your business grow.

With the Partners Incentive Program, you can earn rewards based on the equipment and systems you sell. As a loyal member of the Partners Incentive Program, you will discover an extensive array of exciting rewards to choose from such as trips, merchandise, and much more!

The more you sell, the greater your reward. And selling combinations of four or more product categories gives you additional incentive opportunities.

**GET  
PIP  
POINTS**



So, go ahead and enroll. We have created rewards program tailored to your business

## Who can join?

This program is only for builders, retailers and service companies in the swimming pool industry.

## How does it work?

We want to encourage pool professionals to sell our equipment, and in turn, we want to reward them for their efforts. For every sold product they can earn points, which can be redeemed at the end of the year against all sorts of gifts.

## How to get points?

Attached to our products, there is a program card. By returning this card to us, the dealer will get the points.

## What are the gifts?

PIP program members can earn a fabulous trip to 'Paradise', fine jewelry and watches, LCD televisions, photo cameras and other electronic devices, sports equipment and so much more...

## Literature

Order and/or download free Pentair product brochures and product catalogs.

## For more info:

Please contact the PIP Team by phone 0032 14 25 99 02 or just send an e-mail to [pip.poolemea@pentair.com](mailto:pip.poolemea@pentair.com)

- \* Track your points earned
- \* Redeem points for cash, merchandise, travel, equipment training workshops and more!
- \* Order sales aids & point of purchase materials
- \* Track current orders
- \* See order history
- \* Online Calculators & Tools
- \* Sales & Marketing Tips
- \* Product & Dealer News



a flexible and simple needs.

Enroll now!  
0032 14 25 99 02

## Multi-Cyclone

- Heavy sediment is spun out by the strong centrifugal effect.
- Clear sediment chamber aids inspection
- Easy cleaning by opening one valve
- Only 15 litres of water is used to cleanse
- Easy to install to most existing filtration systems with supplied quick fit unions



### Multi-Cyclone

DISCOUNT/ PRODUCT CODE	DESCRIPTION	PRICE EACH
O 200374 MC12 – 1.5"/50mm		323.00
O 200375 MC16 – 2"/63mm		249.00

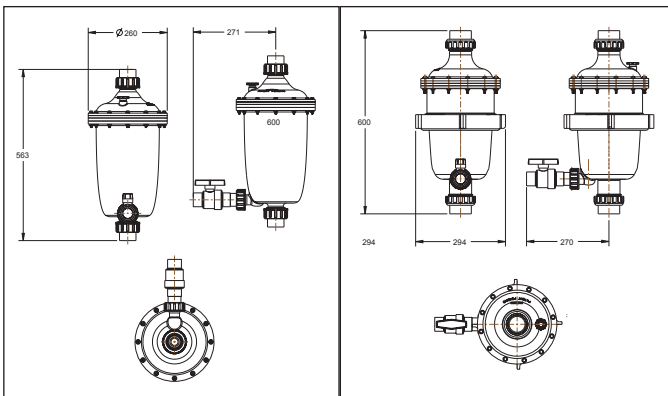

MC12

MC16



## Multi-Cyclone Plus

- All the benefits of a regular Multi-Cyclone but with the addition of a 40 sq ft cartridge
- MC12 designed for pool sizes up to 55m<sup>3</sup>
- MC16 designed for pool sizes up to 80m<sup>3</sup>



### Multi-Cyclone Plus

DISCOUNT/ PRODUCT CODE	DESCRIPTION	PRICE EACH
O 200380 MC12(40) c/w 40 sq ft Cartridge – 1.5"/50mm		494.00
O 200381 MC16(40) c/w 40 sq ft Cartridge – 2"/63mm		597.00
O 62451 40 sq ft Cartridge		85.00

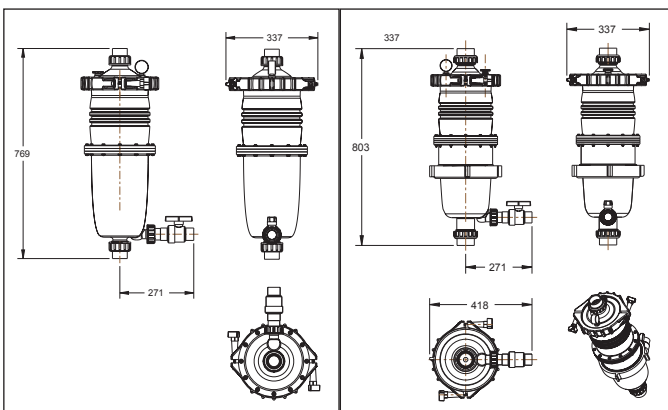

MC12

MC16





# Multi-Cyclone Ultra

- All the benefits of a regular Multi-Cyclone but with the addition of a 75ft<sup>2</sup> cartridge
- MC12 designed for pool sizes up to 81m<sup>3</sup>
- MC16 designed for pool sizes up to 100m<sup>3</sup>



## Multi-Cyclone Ultra

DISCOUNT/ PRODUCT CODE	DESCRIPTION	PRICE EACH
O 200382	MC12(75) c/w 75 sq ft Cartridge – 1.5"/50mm	584.00
O 200383	MC16(75) c/w 75 sq ft Cartridge – 2"/63mm	689.00
O 62453	75 sq ft Cartridge	103.00

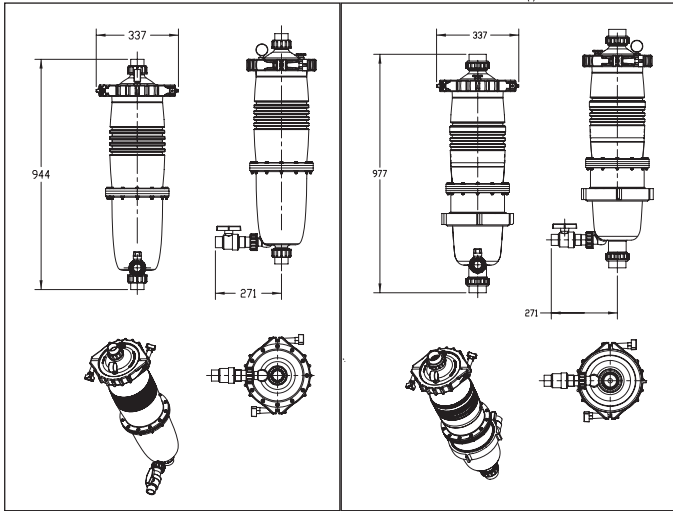

MC12

MC16



Pumps, Filters  
& Heating

# Multi-Cyclone Base Stands

- Suitable for all Multi-Cyclone models
- Base Mk2 measures 400mm (W) x 400mm (H) x 350mm (D)
- Over pump stand measures 795mm (H) x 440mm (W) x 350mm (D)

## Multi-Cyclone Base Stands

DISCOUNT/ PRODUCT CODE	DESCRIPTION	PRICE EACH
O 200373	Mk.1 Multi-Cyclone Base	48.00
O 200372	Mk.2 Multi-Cyclone Base	54.00
O 200370	Multi-Cyclone Over Pump Base	116.00



Mk.1 Multi-Cyclone Base  
200373



Mk.2 Multi-Cyclone Base  
200372



Multi-Cyclone Over-Pump  
Base



# Multiport Valves

## Multiport Valves

DISCOUNT/ PRODUCT CODE	DESCRIPTION	PRICE EACH
K MVA228	6-Way Top Mount (for Waterco Filter Pump Pack) – 1.5"	161.00
K MVA024	6-Way Lacron – 1.5" (white pre 2004)	61.00
K MVA027	6-Way Lacron – 2" (white pre 2004)	96.50
K MVA034	6-Way Lacron/Waterco – 1.5" (black post 2004)	128.00
K 2290512	6-Way Lacron/Waterco 2"/63mm (black post 2004)	178.00



6-Way Top Mount – MVA228

## Multiport Valves

DISCOUNT/ PRODUCT CODE	DESCRIPTION	PRICE EACH
K MVA250	Plastica Top Mount – 1.5"	74.00
K MVA025	6-Way 3D / Max – 1.5"	61.00
K MVA710	Hayward 710 – 1.5"	129.50
K MVA715	Hayward 715 – 2"	202.50



MVA024 / MVA027 / MVA030



Plastica Top Mount – MVA250



6-Way 3D/Max 1.5" – MVA025



Hayward 710 - 1.5" –MVA710

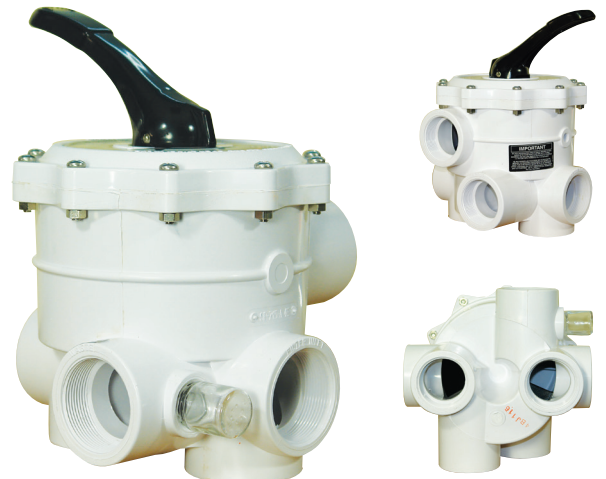

Hayward 715 - 2" – MVA715

Pumps, Filters  
& Heating

# Multiport Valves

## Multiport Valves

DISCOUNT/ PRODUCT CODE	DESCRIPTION	PRICE EACH
K R14965-TM10	6-Way Onga – 1.5"	128.00
K RE261070ND	Triton – 1.5" TRV40/TRV60	170.00
K RE261071ND	Triton – 2" TRV100/TRV140	247.00
K RE272026ND	Azur / Tagelus – 1.5" TAG40/60	194.00

\*While stocks last



RE261071ND / RE261070ND



RE272026ND / RE272029ND

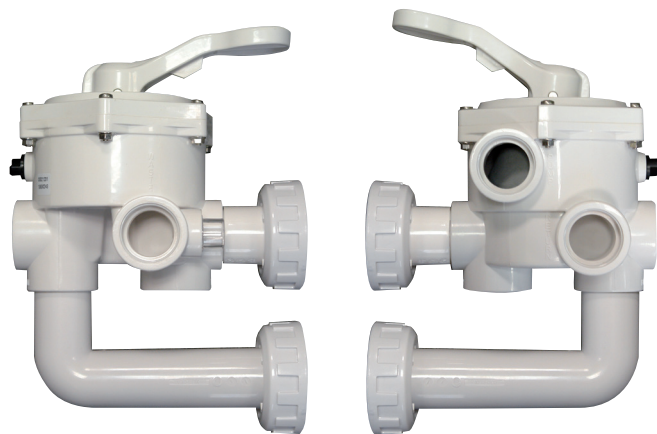

EMV010 / EMV020

## Multiport Valves

DISCOUNT/ PRODUCT CODE	DESCRIPTION	PRICE EACH
K RE272029ND	Tagelus – 2" TAG100	242.00
K MVA150	Allport	82.00
K EMV010	6-Way Endurance Side Mount – 1.5"	101.00
K EMV020	6-Way Endurance Side Mount – 2"	161.00
K SFP010	iFlo 500	70.15



R14965-TMKH – This item is no longer available  
Use R14965-TM10 and adapt pipework



Allport – MVA150



iFlo 500 – SFP010

# Glass Filter Media

HEAVY ITEM

- Improves water clarity
- Removes particles as small as 5 microns
- Pay back period of less than 12 months
- Reduced chemical usage
- Less wastage of heated and treated water
- Resists bacterial contamination



- Longer lasting (no need to replace every 5 years)
- Chloramines greatly reduced
- 50% less water required to backwash
- 10% less media required than sand

## 25kg Bags

DISCOUNT/ PRODUCT CODE	DESCRIPTION	PRICE EACH
T6 GFM001	Grade 1 filter media (0.5 - 1mm)	15.00
T6 GFM003	Grade 3 filter media (3 - 6mm)	15.00
T6 GFM001P	Grade 1 filter media (0.5 - 1mm) 40 bags	550.00

One pallet equals 40 bags of glass filter media.



Pumps, Filters  
& Heating

# Silica Sand Filter Media

HEAVY ITEM

## Silica Sand – 25kg Bags

DISCOUNT/ PRODUCT CODE	DESCRIPTION	PRICE EACH
T6 MVA750	16/30 grade filter media	13.00
T6 MVA750P	16/30 grade filter media 40 bags	480.00

One pallet equals 40 bags of sand filter media.



# Mida Mat Automatic Multiport Valve

- Automatic backwash and filter control
- Digital control
- Easy to install
- Memory card of error
- Automatic pump shutdown prior to position changes
- Easy to install
- Water resistant IP65
- Programmable times for operation and backwashing of the filter



## Mida Mat

DISCOUNT/ PRODUCT CODE	DESCRIPTION	PRICE EACH
K 310-A	1.5" Automatic Backwash Valve	885.00
K 320-A	2" Automatic Backwash Valve	999.00

## Pressure Gauges

### Pressure Gauges

DISCOUNT/ PRODUCT CODE	DESCRIPTION	PRICE EACH
K MVA402	50mm Side Mount 0-90psi – 0.25" BSPT	9.50
K MVA404	50mm Side Mount 0-30psi – 0.125" BSPT	9.50
K TFT10003	50mm Back Mount 0-60psi – 0.25" BSPT	9.45
K EFI010	Endurance Back Mount – 0.125" BSPT	9.60



MVA402 – TFT10003 – MVA404 – EFI010

## Reinforced Backwash Hoses

### Reinforced Backwash Hose

DISCOUNT/ PRODUCT CODE	DESCRIPTION	PRICE EACH
H RBW015	15m Reel	50.50
H RBW030	30m Reel	101.00



## Backwash Hose

### 1.5" Backwash Hose

DISCOUNT/ PRODUCT CODE	DESCRIPTION	PRICE EACH
M PBW050	15m Reel	14.00
M PBW100	30m Reel	28.00

### 2" Backwash Hose

DISCOUNT/ PRODUCT CODE	DESCRIPTION	PRICE EACH
M PBW051	15m Reel	16.00



## Hose Clips

### Hose Clip

DISCOUNT/ PRODUCT CODE	DESCRIPTION	PRICE EACH
B JUB087	Small (13-20mm)	3.60
B JUB162	Medium (30-40mm)	3.90
B JUB212	Large (45-60mm)	5.70



# Genie Gas Heater (MB35 & MB50)

SPECIAL  
ORDER

HEAVY  
ITEM



- 20kW (68,000 Btu), 35kW (118,000 Btu), 50kW (170,000 Btu)
- Natural or propane gas (conversion kit for propane included)
- Up to 94% condensing efficiency SEDBUK A
- Pre-plumbed with double non-return valve
- Reduce running costs by up to 30%
- Environmentally friendly
- Modulating output for accurate control
- IP44 for indoor/outdoor installations
- Quiet running
- Compact design
- Multiple heater kit option
- Suitable for salt chlorinated pools
- Left or right hand connections
- Simple condensate disposal connections
- Plastic push-fit flue kit (not included with heater)
- Honeywell CVI controls
- Wall mountable
- Modulating output for accurate temperature control
- 1.5" connections



## Certikin Genie

DISCOUNT/ PRODUCT CODE	DESCRIPTION	PRICE EACH
H MB20S ▲	20kW (68,000 Btu)	2725.00
H MB35S ▲	35kW (118,000 Btu)	3020.00
H MB50S ▲	50kW (170,000 Btu)	3695.00

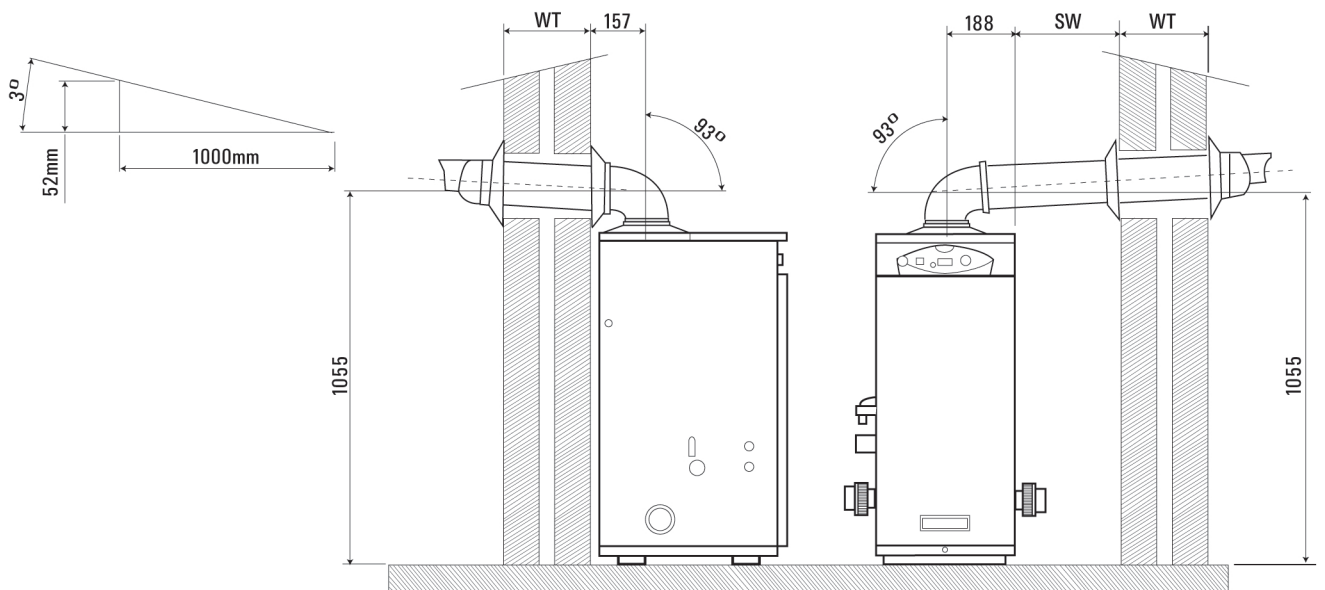

## Genie Flue & Multiple Heater Kits

### Balanced Flue Kits

DISCOUNT/ PRODUCT CODE	DESCRIPTION	PRICE EACH
H MBOT ▲	Outdoor Terminal	145.00
H MBHT ▲	Horizontal Terminal	66.00
H MBVT ▲	Vertical Terminal	130.00
H MBHVE ▲	1m Flue Extension Pipe (horizontal or vertical)	61.50
H MB90DB ▲	90° Flue Bend	61.50
H MB45DB ▲	45° Flue Bend - pair	110.00
H MBWMK35/50 ▲	Wall Mount Kit	75.00

### Multiple Heater Installation Kits

DISCOUNT/ PRODUCT CODE	DESCRIPTION	PRICE EACH
H MBM1K2 ▲	2 heater	314.00
H MBM1K3 ▲	3 heater	465.00
H MBM1K4 ▲	4 heater	620.00
H MBM1K5 ▲	5 heater	POA

# Certikin Oil Heater

SPECIAL  
ORDER

HEAVY  
ITEM



## Oil Heaters

DISCOUNT/ PRODUCT CODE	DESCRIPTION	PRICE EACH
K COH110	▲ 32kW (110,000 Btu) – 4" flue	3315.00
K COH180	▲ 52kW (180,000 Btu) – 5" flue	3995.00
K COH220	▲ 65kW (220,000 Btu) – 5" flue	4335.00
K COH280	▲ 82kW (280,000 Btu) – 6" flue	5720.00

## Horizontal Balanced Flue Kits

DISCOUNT/ PRODUCT CODE	DESCRIPTION	PRICE EACH
K SPCOHBFB1	▲ for COH110	255.00
K SPCOHBFB1L	▲ for COH110 (long)	372.00
K SPCOHBFB2	▲ for COH180/220	410.00
K SPCOHBFB2L	▲ for COH180/220 (long)	476.00
K SPCOHBFB3	▲ for COH280	655.00

## Outdoor Terminals

DISCOUNT/ PRODUCT CODE	DESCRIPTION	PRICE EACH
K SPCOHBFOV10	▲ for COH110	293.00
K SPCOHBFOV11	▲ for COH180/220	293.00
K SPCOHBFOV3	▲ for COH280	303.00

## Indoor Vertical Balanced Flu Adaptors

DISCOUNT/ PRODUCT CODE	DESCRIPTION	PRICE EACH
K SPCOHBFBIV1	▲ for COH110/180	477.00
K SPCOHBFBIV2	▲ for COH220	620.00
K SPCOHBFBIV3	▲ for COH280	477.00

## Indoor Vertical Balanced Flu Extensions

DISCOUNT/ PRODUCT CODE	DESCRIPTION	PRICE EACH
K SPCOHBFBV11E	▲ 1m for COH110/180	173.00
K SPCOHBFBV21E	▲ 870mm for COH220/280	238.00
K SPCOHBFBV15E	▲ 500mm for COH110/180	112.00
K SPCOHBFBV25E	▲ 460mm for COH220/280	179.00

## Terminal Guards

DISCOUNT/ PRODUCT CODE	DESCRIPTION	PRICE EACH
K SPCOHTG1	▲ for COH110/180/220	25.00
K SPCOHTG2	▲ for COH280	116.00

- Easy to use diagnostic electronic controls
- LED display
- Suitable for salt water pools
- Quiet operation
- Fitted with Riello burners
- Optional balanced or vertical balanced flue kit
- Fully tested and approved to OFTEC and EC standards
- Pre-plumbed for simple installation
- IP44 rated outdoor terminals



Pumps, Filters  
& Heating

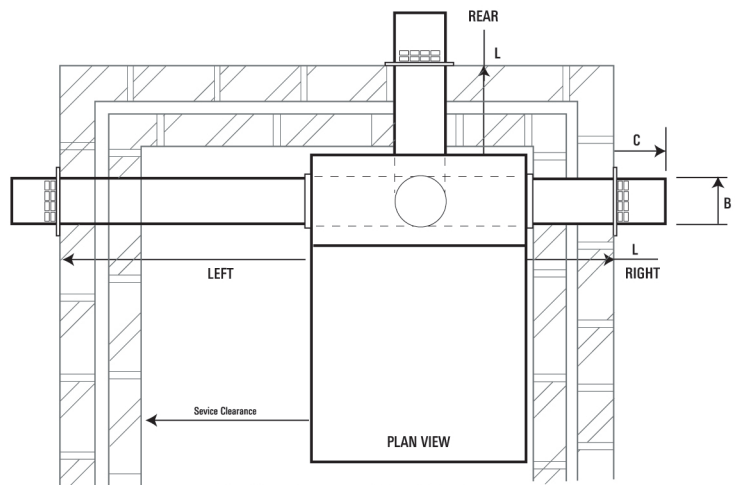
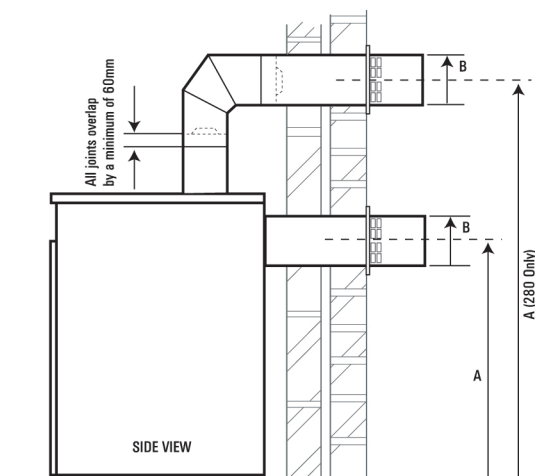

# Heat Exchangers

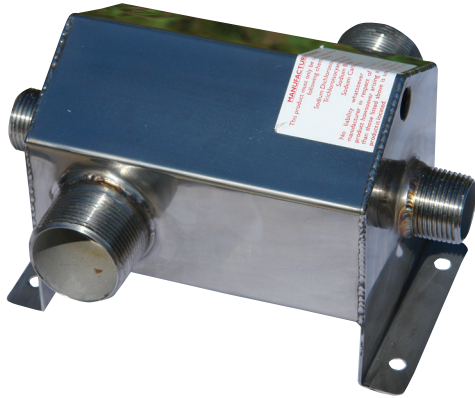

Heat Exchanger 17.5kW – WHE060

- Ideal for installation on a household heating system
- Stainless steel
- Built in 0.5" Probe Pocket

Note: The value of the unit should be matched to or below the heat value of the household heater.



Heat Exchanger 50kW – WHE170

## Stainless Steel Heat Exchangers

DISCOUNT/ PRODUCT CODE	DESCRIPTION	PRICE EACH
O WHE060	17.5kW (60,000 Btu) 1.5" M/T	341.00
O WHE100	30kW (100,000 Btu) 1.5" M/T	357.00
O WHE130	38kW (130,000 Btu) 1.5" M/T	400.00
O WHE170	50kW (170,000 Btu) 1.5" M/T	424.00
O WHE230	67kW (230,000 Btu) 2" M/T	518.00
C PPF116	1.5" Composite Union	26.40
C PPF216	2" Composite Union	39.40

# Bowman Heat Exchangers



- Cupro-nickel tubes
- Plastic ends
- Non-threaded thermostat pocket
- Both 1.5" and 50mm unions supplied
- New EC80 model delivers up to 20kW heat transfer, ideal for small pools and spas

## Bowman Heat Exchangers

DISCOUNT/ PRODUCT CODE	DESCRIPTION	PRICE EACH
K EC80-5113-1S	20kW (68,000 Btu)	216.00
K 5113-3C	70kW (240,000 Btu)	294.00
K 5114-2C	100kW (340,000 Btu)	420.00

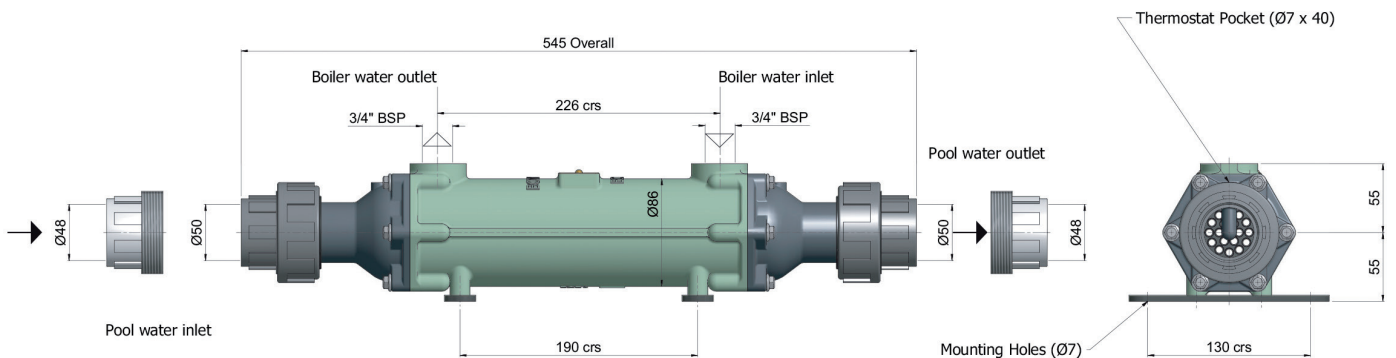



# Elecro Generation 2 Titanium Heat Exchangers



- Robust, durable construction
- Wall mountable (bracket supplied)
- 316 stainless steel shell with special polyimide fittings
- 37 piece Titanium internal tube bundle
- For indoor or outdoor pools
- Thermostat Pocket
- Solvent weld unions for connection to rigid pipe 1.5"/50mm connections
- Suitable for salt, chlorinated and solar heated pools

## Generation 2 Titanium Heat Exchangers

DISCOUNT/ PRODUCT CODE	DESCRIPTION	PRICE EACH
H G2-HE-30T	30kW (102,000 Btu)	315.00
H G2-HE-49T	49kW (167,000 Btu)	390.00
H G2-HE-85T	85kW (290,000 Btu)	490.00
H G2-HE-122T	122kW (416,000 Btu)	670.00

These heat exchangers come with a 3 year warranty.

The G2 Heat Exchanger has been designed to allow the installation engineers to select which way to plumb the primary and secondary water to achieve maximum thermal gain. This is achieved by rotating the primary (hot) flow in an opposing direction to the secondary (pool) water.

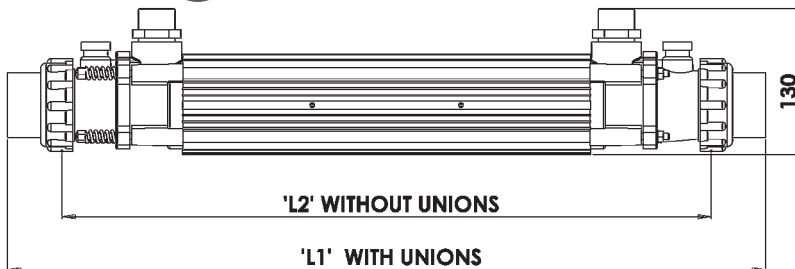
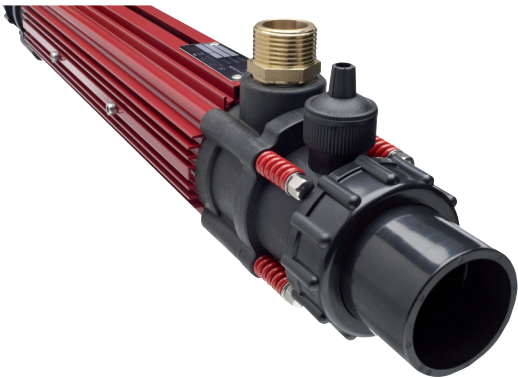

Titanium Tube Bundle Product Code	Standard Power Output	Dimensions 'L1'	Dimensions 'L2'
G2-HE-30T	30kW (102,000 BTU)	540mm	426mm
G2-HE-49T	49kW (167,000 BTU)	710mm	596mm
G2-HE-85T	85kW (290,000 BTU)	840mm	726mm
G2-HE-122T	122kW (416,000 BTU)	1000mm	886mm

Pumps, Filters  
& Heating

# HeatSeeker™ Horizontal Heat Pump

- Proven reliability
- Remote digital control panel
- Titanium heat exchanger
- High efficiency compressor
- Self diagnostic
- Fully programmable
- Quick and easy installation
- Strong steel casing
- Very quiet operation
- Reverse cycle defrost
- Bypass kit contains all fittings required including pipe and glue



Pumps, Filters  
& Heating

## Horizontal

DISCOUNT/ PRODUCT CODE	DESCRIPTION	PRICE EACH
K HSE056 5.6kW		1224.00
K HSE095 9.5kW		1612.00
K HSE125 12.5kW		1858.00

## Horizontal Accessories

DISCOUNT/ PRODUCT CODE	DESCRIPTION	PRICE EACH
K HCH100	Winter Cover for Horizontal HeatSeeker	69.00
K HSE500	HeatSeeker Bypass Kit	73.20



Model	Pool Volume
5.6kW	20m <sup>3</sup>
9.5kW	35m <sup>3</sup>
12.5kW	50m <sup>3</sup>

Recommended maximum pool volume for HeatSeekers

This sizing chart assumes that a pool is being heated from May to September, the desired pool temperature is 29°C, the ambient air temperature is not less than 15°C and a heat retention cover is used.

Model	Running Current	Start-Up Current
5.6kW	3.6 Amps	15 Amps
9.5kW	8.8 Amps	35 Amps
12.5kW	11.6 Amps	46 Amps

**i** It is strongly recommended that checks are made in relation to starting amps and load requirements for these machines.

HeatSeekers come with a 2 year parts and labour warranty. 5 years warranty on the titanium heat exchanger. 12 months parts only warranty on all units sold out of the UK mainland.

HeatSeeker is a registered trademark of Plastica Ltd.

# HeatSeeker™ Vertical Heat Pump

- Proven reliability
- Remote digital control panel
- Titanium heat exchanger
- High efficiency compressor
- Self diagnostic
- Fully programmable
- Quick and easy installation
- Strong steel casing
- Very quiet operation
- Reverse cycle defrost
- Bypass kit contains all fittings required including pipe and glue
- Soft start models typically lower startup amps by at least 50%



Pumps, Filters & Heating

## Vertical

DISCOUNT/ PRODUCT CODE	DESCRIPTION	PRICE EACH
K HSE170 17kW		2940.00
K HSE170S 17kW c/w Soft Start Motor Controller		3390.00
K HSE210 21kW		3210.00
K HSE210S 21kW c/w Soft Start Motor Controller		3660.00



## Vertical Accessories

DISCOUNT/ PRODUCT CODE	DESCRIPTION	PRICE EACH
K HCV100	Winter Cover for Vertical HeatSeeker	79.00
K HSE500	HeatSeeker Bypass Kit	73.20



Model	Pool Volume
17kW	70m <sup>3</sup>
21kW	85m <sup>3</sup>

Recommended maximum pool volume for HeatSeekers

This sizing chart assumes that a pool is being heated from May to September, the desired pool temperature is 29°C, the ambient air temperature is not less than 15°C and a heat retention cover is used.

Model	Running Current	Start-Up Current
17kW	16.1 Amps	65 Amps
21kW	21 Amps	84 Amps



It is strongly recommended that checks are made in relation to starting amps and load requirements for these machines.

HeatSeekers come with a 2 year parts and labour warranty. 5 years warranty on the titanium heat exchanger. 12 months parts only warranty on all units sold out of the UK mainland.

Start-up current can be over five times the running current. The power supply to these units must be suitably specified and robustly installed.

HeatSeeker is a registered trademark of Plastica Ltd.



## Reverse Cycle Defrost – Year round usage

- Minimum operating air temperature: -15° C
- 52 week application (indoor or outdoor)
- 3 years parts and labour UK warranty

### Single Phase Reverse Cycle Defrost

DISCOUNT/ PRODUCT CODE	DESCRIPTION	PRICE EACH
F PPT8ALYN ▲	Pro-Pac-8	3940.00
F PPT8ALYSN ▲	Pro-Pac-8 with Soft Start	4355.00
F PPT12ALN ▲	Pro-Pac-12	4690.00
F PPT12ALYSN ▲	Pro-Pac-12 with Soft Start	5110.00
F PPT16ALYN ▲	Pro-Pac-16	5740.00
F PPT16ALYSN ▲	Pro-Pac-16 with Soft Start	6285.00
F PPT22ALYN ▲	Pro-Pac-22	6565.00
F PPT22ALYSN ▲	Pro-Pac-22 with Soft Start	7120.00

### Three Phase Reverse Cycle Defrost

DISCOUNT/ PRODUCT CODE	DESCRIPTION	PRICE EACH
F PPT12BLYN ▲	Pro-Pac-12	4785.00
F PPT16BLYN ▲	Pro-Pac-16	5895.00
F PPT22BLYN ▲	Pro-Pac-22	6575.00

## Hot Gas Defrost – X Range

- Minimum operating air temperature: 7° C
- Extended summer season for outdoor pools (April - October, May - September)
- 3 years parts and labour UK warranty

### Single Phase Hot Gas Defrost

DISCOUNT/ PRODUCT CODE	DESCRIPTION	PRICE EACH
F PPT8ALX ▲	8kW Extended Season	2695.00
F PPT12ALX ▲	12kW Extended Season	3135.00
F PPT12ALXS ▲	12kW with Soft Start Extended Season	3625.00
F PPT16ALX ▲	16kW Extended Season	3865.00
F PPT16ALXS ▲	16kW with Soft Start Extended Season	4300.00
F PPT22ALX ▲	22kW Extended Season	4555.00
F PPT22ALXS ▲	22kW with Soft Start Extended Season	5050.00



### Three Phase Hot Gas Defrost

DISCOUNT/ PRODUCT CODE	DESCRIPTION	PRICE EACH
F PPT12BLX ▲	12kW Extended Season	3585.00
F PPT16BLX ▲	16kW Extended Season	4095.00
F PPT22BLX ▲	22kW Extended Season	4710.00
F PPT22BLXS ▲	22kW with Soft Start Extended Season	5175.00



It is strongly recommended that checks are made in relation to starting amps and load requirements for these machines.

NEW FOR  
2017

## Relax Pool Dehumidifiers

DISCOUNT/ PRODUCT CODE	DESCRIPTION	PRICE EACH
K RDW030	▲ Relax Pool Dehumidifier (3L/H)	2495.00
K RDW043	▲ Relax Pool Dehumidifier (4.3L/H)	2865.00

### • High efficiency

Dehumidification volume of Relax Pool Dehumidifiers reaches up to 4.3 Litres per hour (30°C ambient temperature and 80% relative humidity).

### • Epoxy Fin Air Exchanger

Specially designed Epoxy Fin Air Exchanger for optimum performance and anti-corrosion, ensuring a longer working life.

### • Super silent running

Relax Pool Dehumidifiers use DC fan motors for air circulation, producing less than 48dB, making the unit incredibly quiet.

### • Sleek, ultra-thin casing

With compact inner structure, Relax Pool Dehumidifiers feature ultra-thin casing of 200mm, requiring minimum space in the pool room.

### • Wall mounted (see diagram)

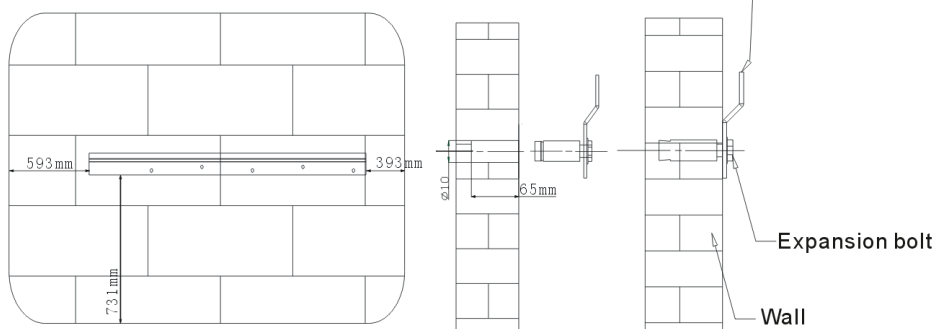

Model	Measurements	RDW030	RDW043
Rated Capacity	Litres per hour	3.0	4.3
Dehumification Capacity/Day	Litres	72	103
Recommended Pool Area	Meters <sup>2</sup>	60	83
Noise Level	dB (A)	46	48
Rated Voltage/Frequency	/	220-240v ~ 50Hz	220-240v ~ 50Hz
Rated Power Input	kW	1.13	1.97
Rated Running Current	Amp	5	8.7
Max. Power Input	kW	1.32	2.28
Max. Running Current	Amp	5.85	10
Relative Humidity	% Relative Humidity	40-90	40-90
Temperature	Degrees Celcius	10 ~ 36	10 ~ 36
Dimensions (L/W/H)	mm	1495/200/648	1495/200/648
Refridgerant	/	R410A	R410A
Condensation Pipe Dia.	mm	16	16

# Monitair Single Phase Dehumidifiers

HEAVY ITEM

- Floor mount or thru-the-wall models
- 2 years parts and labour warranty (UK only)
- Equipped with a variable humidistat for automatic control
- Defrost facility as standard

## Monitair

DISCOUNT/ PRODUCT CODE	DESCRIPTION	PRICE EACH
F DH44AX ▲	44 Dehumidifier + Defrost	2235.00
F DH66AX ▲	66 Dehumidifier + Defrost	3440.00
F DH75AX ▲	75 Dehumidifier + Defrost	3975.00
F DH110AX ▲	110 Dehumidifier + Defrost	4575.00

## Monitair Thru-the-Wall

DISCOUNT/ PRODUCT CODE	DESCRIPTION	PRICE EACH
F DH75AX/T ▲	75 Dehumidifier + Defrost	4260.00
F DH110AX/T ▲	110 Dehumidifier + Defrost	4880.00

## Monitair Thru-the-Wall with LPHW Air

DISCOUNT/ PRODUCT CODE	DESCRIPTION	PRICE EACH
F DH75AX/TL ▲	75 Dehumidifier + Defrost + Air Heating	4900.00
F DH110AX/TL ▲	110 Dehumidifier + Defrost + Air Heating	5500.00



## Monitair with LPHW Air Heating

DISCOUNT/ PRODUCT CODE	DESCRIPTION	PRICE EACH
F DH44AX/L ▲	44 Dehumidifier + Defrost + Air Heating	2410.00
F DH66AX/L ▲	66 Dehumidifier + Defrost + Air Heating	3705.00
F DH75AX/L ▲	75 Dehumidifier + Defrost + Air Heating	4595.00
F DH110AX/L ▲	110 Dehumidifier + Defrost + Air Heating	5195.00

# Vaporex Dehumidifiers

SPECIAL ORDER

HEAVY ITEM

- Wall mounted
- Vaporex 34 + LPHW (low pressure hot water battery) output 3kW
- Vaporex 56 + LPHW output 5kW.
- 2 years parts and labour UK warranty

## Standard

DISCOUNT/ PRODUCT CODE	DESCRIPTION	PRICE EACH
F DH34A ▲	33 Dehumidifier only	1835.00
F DH56A ▲	56 Dehumidifier only	2650.00

## Defrost

DISCOUNT/ PRODUCT CODE	DESCRIPTION	PRICE EACH
F DH34AX ▲	33 Dehumidifier + Defrost	2095.00
F DH56AX ▲	55 Dehumidifier + Defrost	2955.00

## With LPHW - Integral Heater Coil

DISCOUNT/ PRODUCT CODE	DESCRIPTION	PRICE EACH
F DH34A/L ▲	33 Dehumidifier + (LPHW) Heating	1990.00
F DH34AX/L ▲	33 Dehumidifier + Defrost + (LPHW) Heating	2265.00
F DH56A/L ▲	56 Dehumidifier + (LPHW) Heating	2845.00
F DH56AX/L ▲	56 Dehumidifier + Defrost + (LPHW) Heating	3145.00

Standard – heat recovery to pool hall air.  
Minimum operating air temperature: 17° C.

Defrost – heat recovery to pool hall air.  
Minimum operating air temperature: 0° C.

LPHW – These units require low pressure boiler water controlled by an air thermostat (supplied) at 80°C for outputs stated.

Through wall kit comes with duct sleeve and grille kit for walls up to 150mm thick.



## Through Wall Adapted

DISCOUNT/ PRODUCT CODE	DESCRIPTION	PRICE EACH
F DH33A/T ▲	33 Standard Through Wall	2485.00
F DH33AX/T ▲	33 + Defrost Through Wall	2690.00
F DH33A/TL ▲	33 + 3kW (LPHW) Through Wall	2625.00
F DH33AX/TL ▲	33 + Defrost + 3kW (LPHW) Through Wall	2825.00
F DH55A/T ▲	55 Standard Through Wall	3080.00
F DH55AX/T ▲	55 + Defrost Through Wall	3300.00
F DH55A/TL ▲	55 + 5kW (LPHW) Through Wall	3270.00
F DH55AX/TL ▲	55 + Defrost + 5kW (LPHW) Through Wall	3490.00

## Optional Fascia

DISCOUNT/ PRODUCT CODE	DESCRIPTION	PRICE EACH
F DH34COVERW ▲	34 Vaporex White Fascia Cover	150.00

# Nano Plug & Play Heater



- Titanium elements
- Safety thermal cut-out included (manual reset)
- 2m power cord with UK plug
- 230V single phase 13amp load
- Flow switch - no pump interlock required
- Fully pre-wired
- Control thermostat
- 3 year warranty

## Nano Plus & Play Heater

DISCOUNT/ PRODUCT CODE	DESCRIPTION	PRICE EACH
H N-AGP-UK-T	3kW	331.60

Supplied connection options:

- 1.5" female threaded
- 50mm plain female socket unions
- 1.5" plain female socket unions
- 1.5" / 1.25" hosetail connectors



Can be mounted horizontal or vertical

Pumps, Filters & Heating



Looking for competitive Pump, Filter & Heating prices?

Why not contact us NOW

☎ 01424 857857

📄 01424 875858

✉ info@plasticapools.net

🌐 www.plasticapools.net

Find us on     

# Elecro EVO Electric Heaters with Titanium Elements



- Titanium elements
- Reversible flow switch
- No pump interlock is required
- Fully controlled with Schneider contactor for super safe operation
- May be wall or floor mounted using swivel foot
- BS 316L Stainless Steel flow tube (ENI.4432) as standard
- ABS Solvent weld unions for 1.5"/50mm rigid pipe and hose tails for 1.25"/1.5mm flexible pipe
- 100% operational efficiency throughout product life
- 3 year warranty



Pumps, Filters & Heating

## Three Phase

DISCOUNT/ PRODUCT CODE	DESCRIPTION	PRICE EACH
H 8T36V 6kW*		684.00
H 8T39V 9kW*		694.00
H 8T3AV 12kW*		704.00
H 8T3B 15kW*		713.00
H 8T3C 18kW*		784.00
H 8T3D 24kW*		813.00

## Single Phase

DISCOUNT/ PRODUCT CODE	DESCRIPTION	PRICE EACH
H 8T83 3kW		548.00
H 8T84 4.5kW		553.00
H 8T86 6kW		560.00
H 8T89 9kW		603.00
H 8T8A 12kW		617.00
H 8T8B 15kW		685.00
H 8T8C 18kW		736.00

EVO Heaters marked with \* are Special Order items

### Single Phase

Power Output	Volt	Amp
3kW	230v	13
4.5kW	230v	20
6kW	230v	27
9kW	230v	40
12kW	230v	53
15kW	230v	66
18kW	230v	79



**Bespoke Sales LTD.**  
 sales@bespokepoolsales.co.uk  
 (UK) Tel: 1 001268 710425



# Thermecro Evacuated Tube Solar Heating Systems



Thermecro Evacuated Tube technology converts 92% of solar radiation into heating your pool water.

Thermecro is built to last, constructed from materials such as Titanium and Polymer alloys, it has been engineered to withstand the harshest of climates.

Thermecro's integral ground support frame, pre-fitted solar controller and PEX pipe kit insures that installation is both fast and hassle-free.

- The most efficient way of harvesting the sun's energy
- Absorbs 92% of radiation that strikes the collector
- Achieves significantly higher pool water temperatures than alternative solar collectors
- Delivers heat regardless of ambient air temperature
- Will heat your pool even on cold but sunny days
- 3 year warranty

Thermecro has been designed to maintain a pool temperature of 28° - 29°C during a typical UK summer (June to September). A secondary direct heat source is recommended to help achieve desired pool temperature as quickly as possible at the start of the pool season and during periods of inclement weather conditions.

System includes everything you need including Solar Controller, Interface Valve, 30m of PEX pipe and fittings.

## Thermecro Solar Heating System

DISCOUNT/ PRODUCT CODE	DESCRIPTION	PRICE EACH
F TSS16	▲ 16 Tube set complete kit	2128.00
F TSS32	▲ 32 Tube set complete kit	3107.00
F TSS48	▲ 48 Tube set complete kit	4072.00

Model	Maximum Pool Surface Area
16 Tube set complete kit	14 square metres
32 Tube set complete kit	28 square metres
48 Tube set complete kit	42 square metres

Please obtain a quote for carriage on these products

Pumps, Filters  
& Heating



Solar Controller

Interface Valve



Evacuated Tube Solar

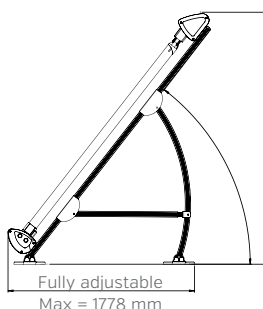
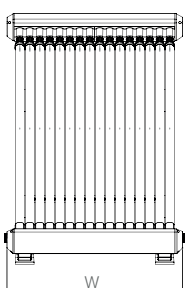

Fully adjustable  
Max = 1241 mm

Fully adjustable  
Max = 1778 mm

Model TSS16 width 1124mm  
Model TSS32 width 2148mm  
Model TSS48 width 3180mm

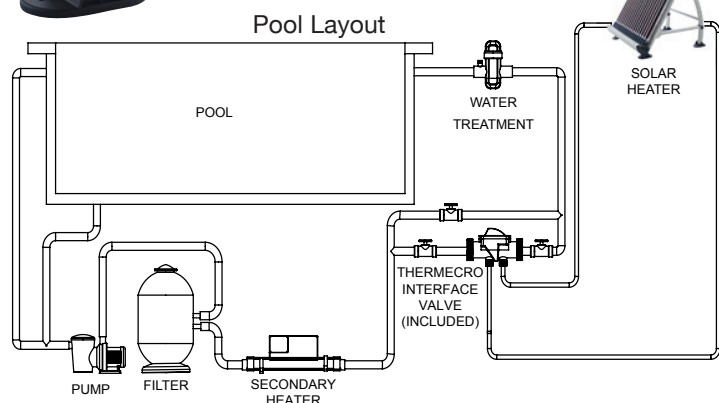

# Elecro Titan Optima Plus



Pumps, Filters  
& Heating

- Easy to install
- Safe, robust and reliable
- Easy touch screen programming
- Floor or wall mountable (bracket supplied)
- Digital water flow signal – no pump interlock required
- Full Titanium construction, flow tubes and heating elements – zero corrosion guaranteed
- Dual cascade wired Schneider Electric contactors on each element bank
- Digital timers for staged energisation (soft start)
- Optional Titan Optima is designed to be used in all pool chemistry applications including sea water.
- 100% operational efficiency throughout product life
- Unit can be vertically wall mounted (brackets supplied)
- 3 year warranty

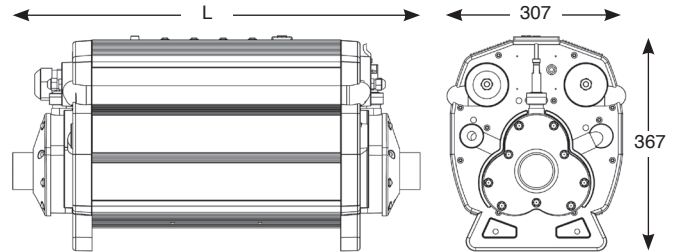

## Titan Optima Plus

DISCOUNT/ PRODUCT CODE	DESCRIPTION	PRICE EACH
H CP-18	18kW	2471.00
H CP-24	24kW	2515.00
H CP-30	30kW	2559.00
H CP-36	36kW	3026.00
H CP-45	45kW	3076.00
H CP-54	54kW	3181.00
H CP-60	60kW	3333.00
H CP-72	72kW	3996.00
H CP-96	96kW	4992.00
H CP-120	120kW	6132.00

### Three Phase

Power Output	Volt	Amp	Length 'L'
18kW	400v	26	699mm
24kW	400v	35	699mm
30kW	400v	44	699mm
36kW	400v	52	699mm
45kW	400v	66	877mm
54kW	400v	78	877mm
60kW	400v	87	1042mm
72kW	400v	104	1042mm
96kW	400v	139	1042mm
120kW	400v	174	1042mm

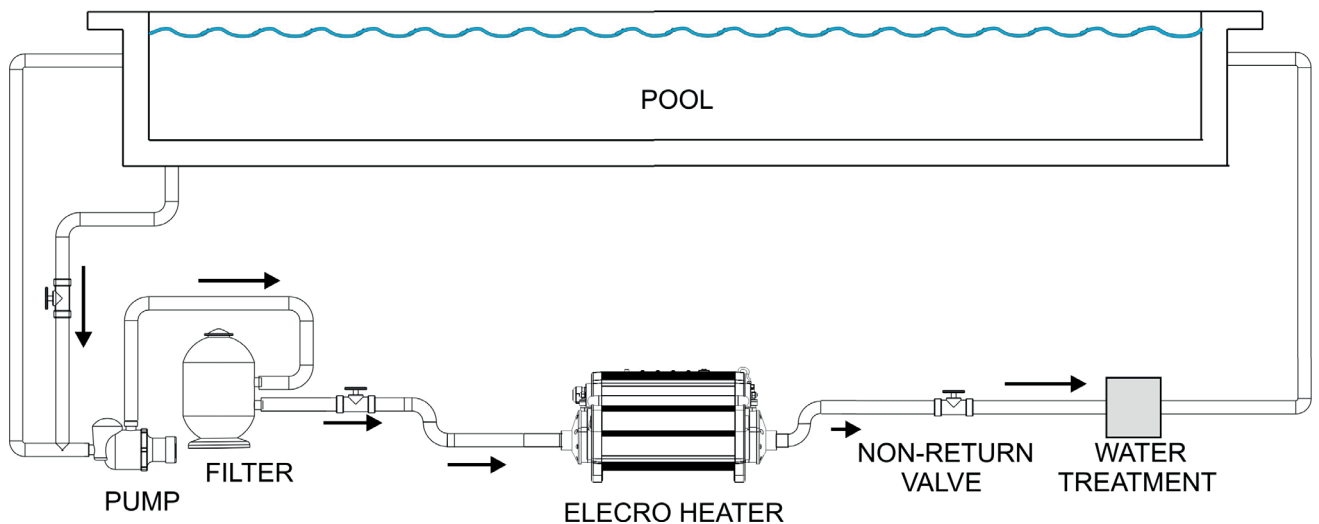

# PoolSmart Plus Digital Controller



NEW FOR 2017

- BMS Building Management System Integrated ready
- Priority of heating, takes control of the circulation pump to ensure the perfect pool temperature is always maintained
- 24-hour programmable time clock
- 0°C to 45°C required temperature range, with 0.5°C differential
- Diagnostics display
- 3 year warranty

Options:

PSPC-HE – Will control all Elecro G2 & SST heat exchangers (supplied with 1m flow switch and 1m temperature sensor that fit directly into ports on our products)

The PPC-1.5 – Will control any heating appliance from any manufacturer – this is supplied with 3m flow switch and 3m temperature sensor that are pre-fitted into a 63mm ABS T-Piece and supplied with 1.5” reducers



Pumps, Filters & Heating

## PoolSmart Plus

DISCOUNT/ PRODUCT CODE	DESCRIPTION	PRICE EACH
H PSPC-HE	PoolSmart+ Touch Screen Controller + 1m F/S & 1m NTC	315.00
H PSPC-1.5	PoolSmart+ Touch Screen Controller + 1m F/S & 1m NTC	333.00

## Honeywell Mechanical Thermostat

- For use with stainless steel heat exchangers

### Mechanical Thermostat

DISCOUNT/ PRODUCT CODE	DESCRIPTION	PRICE EACH
O CHP540	Thermostat with Probe (0.5" BSP)	107.00
O CHP545	Pocket (0.5" BSP)	33.00
O CHP547	End Cap 1.5" with Drilled Tapping (0.5" BSP)	4.00

Note: End Cap requires Pocket



Honeywell Thermostat



Thermostat Pocket & End Cap

## Intex 2kW Heater

- Compatible with Easy Set or Metal Frame pools (up to 12')
- 220-240v
- Easy setup and operation
- Water level sensor
- New or retro-fit
- Includes thermometer

### Intex 2kW Heater

DISCOUNT/ PRODUCT CODE	DESCRIPTION	PRICE EACH
L 28684	Intex 2kW Heater	134.00



# In-Ground Solar Heating Panels

- Moulded fibreglass crush-proof header pipes
- Direct flow system for efficient heating and winterisation
- 2 x 0.61m x 6.1m panels
- Uses existing pool pump
- DIY installation

NO INCREASE FOR 2017



System Fixing Kit consists of  
(one kit mounts four heating kits)

- 5 x Stainless Steel Mounting Brackets
- 5 x 2" No.14 Stainless Steel Screws
- 1 x 3.75" Hose
- 2 x Pipe Adaptors
- 1 x End Cap
- 1 x Vacuum Relief End Cap
- 3 x Stainless Steel Clamps
- 100ft Web Strap



System Fixing Kit – SOM003



## Solar Heating Panels

DISCOUNT/ PRODUCT CODE	DESCRIPTION	PRICE EACH
L SOM002	Solar Heating Kit 2 x 0.61m x 6.1m	341.30
L SOM003	System Fixing Kit	210.00
L SOM060	High Wind Kit	35.00

Example Usage		
Pool Size (meters)	Solar Heating Kits required	System Fixing Kits required
4.6 x 9.2	2	1
4.9 x 11	3	1
6 x 12	4	1

Note: System Fixing Kit is also required to fit your solar heating kit

Note: The heating efficiency of Solar Panels is directly related to climatic conditions. Plastica cannot guarantee that solar heating will maintain a constant pool temperature and recommend installation of a secondary heat source.



Solar Heating Kit – SOM002

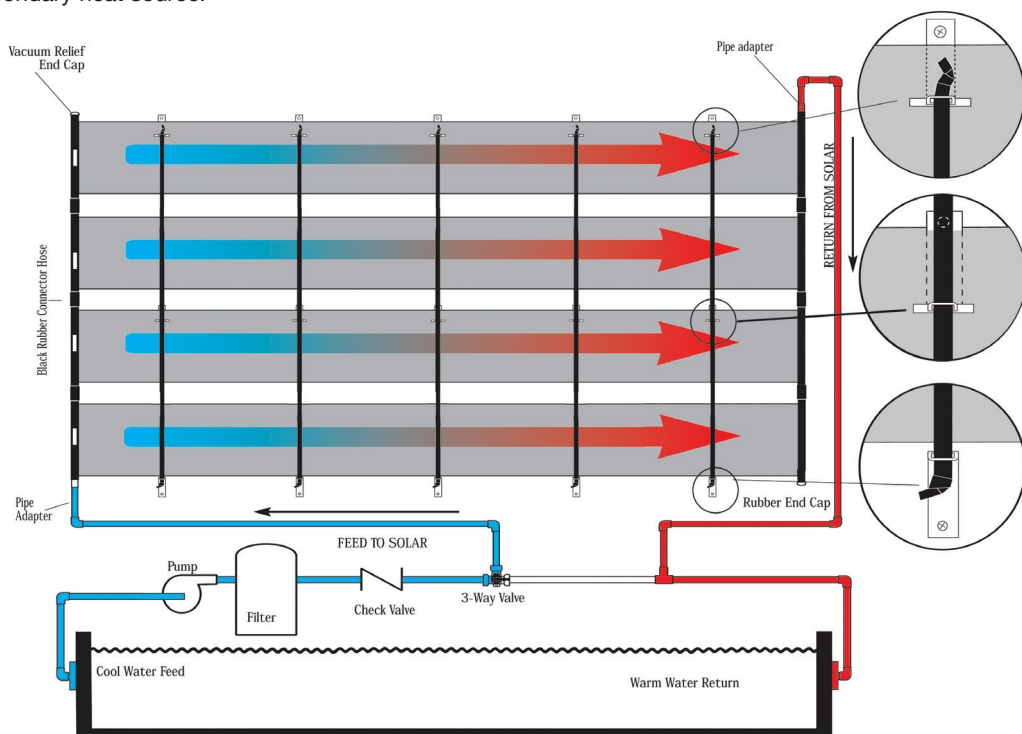

# Above Ground Solar Heating Panels

Kit consists of

- 0.61m x 6.1m Solar Panel
- 2 x End Stops
- 1 x Connector Hose
- 2 x Jubilee Clips
- 2 x Threaded Connector (1.5")
- 1 x PTFE Tape



## Solar Heating Panels

DISCOUNT/ PRODUCT CODE	DESCRIPTION	PRICE EACH
L SOM001	Solar Heating Kit 0.61m x 6.1m	180.80
L SOM010	Hardware Kit	43.95
L SOM011	Connector Hose	9.40
L SOM050	Roof Mounting Kit	52.50
L SOM060	High Wind Kit	35.00
L SOM070	Diverter Valve Kit	52.50

Pumps, Filters & Heating



Diverter Kit – SOM070



High Wind Kit – SOM060



Roof Mounting Kit – SOM050



Hardware Kit – SOM010

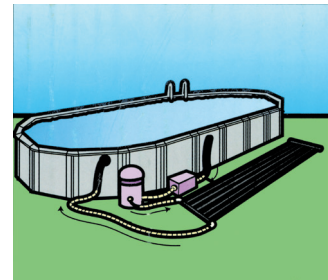
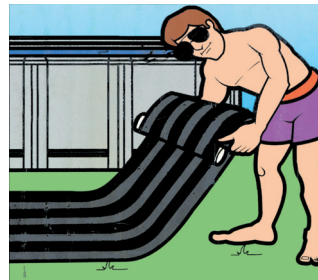
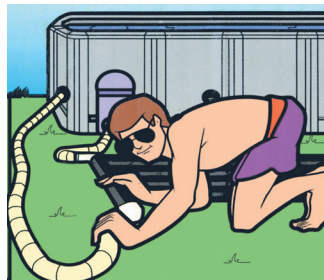
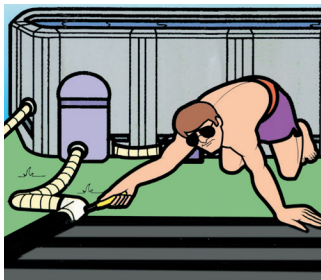

### Recommendations for Round Pools

Pool Diameter (feet)	Pool Diameter (metres)	Recommended No. of Panels
8ft	2.4m	1
12ft	3.6m	3
15ft	4.5m	4
18ft	5.4m	5
24ft	7.3m	9

### Recommendations for Wooden Pools

Pool Diameter (feet)	Pool Diameter (metres)	Recommended No. of Panels
13ft Octagonal	4m Octagonal	3
16ft Octagonal	5m Octagonal	5
20ft Octagonal	6m Octagonal	6
12ft x 18ft	4m x 5.9m	4
12ft x 22ft	4m x 6.9m	5

### Recommendations for Oval Pools

Pool Diameter (feet)	Pool Diameter (metres)	Recommended No. of Panels
16ft x 10ft	4.8m x 3m	3
12ft x 24ft	3.7m x 7.4m	6
12ft x 32ft	3.7m x 9.7m	8

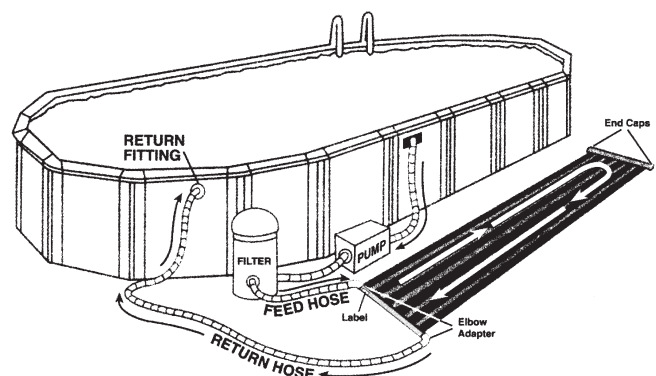

Note: The heating efficiency of Solar Panels is directly related to climatic conditions. Plastica cannot guarantee that solar heating will maintain a constant pool temperature and recommend installation of a secondary heat source.

## Solar Pod™

- For above ground pools
- Compact size of 580mm x 580mm
- Coil made of strong polypropylene
- Strong transparent polycarbonate dome
- Easy connection
- Connect multiple units for larger pools
- Works with existing pool pump\*
- Minimal tools required (Philips screwdriver and silicon lubricant)
- Tilts to achieve best angle for sun
- No servicing required (other than winterising)



- Solar Pod includes:
- 1m and 0.36m hoses
  - Main base with stand
  - 1.25" to 1.5" hose reducer
  - Collared tube adaptor
  - Hose clamps
  - Side hose connector x2
  - Hose ID 38mm
  - Clear dome
  - Solar protection cover

### Solar Pods™

DISCOUNT/ PRODUCT CODE	DESCRIPTION	PRICE EACH
K POD001	Solar Pod	95.00
K POD051	Solar Pod Accessories Kit	10.50
K POD053	Additional Hose (Short – 375mm x 1.5")	6.35
K POD054	Additional Hose (Long – 975mm x 1.5")	16.80

Note: For use with Intex standard filtration you will need to purchase 1.25" hose (see page 163).

Note: The heating efficiency of Solar Pods is directly related to climatic conditions. Plastica cannot guarantee that solar heating will maintain a constant pool temperature and recommend installation of a secondary heat source.

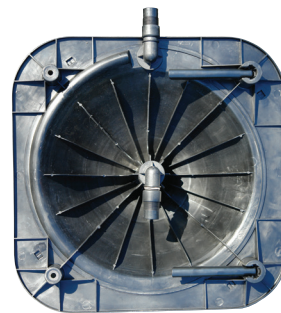

Solar Pod Accessories Kit – POD051

Note: Any more than 3 Solar Pods should be plumbed in parallel.

## Solar Pod™ Plus

- For above ground pools up to 9,000 litres
- 780mm x 780mm x 450mm
- Coil made of strong polypropylene
- Strong transparent dual polycarbonate domes
- Easy connection
- Connect multiple units for larger pools
- Works with existing pool pump\*
- Minimal tools required (Philips screwdriver and silicon lubricant)
- Tilts to achieve best angle for sun
- No servicing required (other than winterising)
- Reflective underside for optimum heat gain



- Solar Pod Plus includes:
- Hose ID 38mm
  - Main base with stand
  - 1.25" to 1.5" hose reducer
  - Collared tube adaptor
  - Hose clamps
  - 1m and 0.36m hoses
  - Side hose connector x2
  - Clear dome
  - Solar protection cover

### Solar Pods™ Plus

DISCOUNT/ PRODUCT CODE	DESCRIPTION	PRICE EACH
K POD002	Solar Pod Plus	199.00
K POD052	Solar Pod Plus Accessories Kit	13.00
K POD053	Additional Hose (Short – 375mm x 1.5")	6.35
K POD054	Additional Hose (Long – 975mm x 1.5")	16.80



Solar Pod Plus Accessories Kit – POD052

Note: The heating efficiency of Solar Pods is directly related to climatic conditions. Plastica cannot guarantee that solar heating will maintain a constant pool temperature and recommend installation of a secondary heat source.